

МИНИСТЕРСТВО ЗДРАВООХРАНЕНИЯ РЕСПУБЛИКИ БЕЛАРУСЬ  
БЕЛОРУССКИЙ ГОСУДАРСТВЕННЫЙ МЕДИЦИНСКИЙ УНИВЕРСИТЕТ  
КАФЕДРА МЕДИЦИНСКОЙ И БИОЛОГИЧЕСКОЙ ФИЗИКИ

**Л. В. КУХАРЕНКО, О. В. НЕДЗЬВЕДЬ**

**ОПТИЧЕСКАЯ, ЭЛЕКТРОННАЯ  
И АТОМНО-СИЛОВАЯ МИКРОСКОПИИ**

**OPTICAL, ELECTRON AND ATOMIC FORCE  
MICROSCOPIES**

Учебно-методическое пособие



Минск БГМУ 2014

УДК 53(811.111)-054.6 (075.8)  
ББК 22.3 (81.2 Англ-923)  
К96

Рекомендовано Научно-методическим советом университета в качестве  
учебно-методического пособия 19.02.2014 г., протокол № 6

Р е ц е н з е н т ы: канд. мед. наук, доц. Т. М. Студеникина; канд. техн. наук, доц.  
В. А. Мансуров

**Кухаренко, Л. В.**

К96 Оптическая, электронная и атомно-силовая микроскопии = Optical, electron  
and atomic force microscopies : учеб-метод. пособие / Л. В. Кухаренко,  
О. В. Недзьведь. – Минск : БГМУ, 2014. – 31 с.

ISBN 978-985-528-962-4.

В издании с физической точки зрения, в доступной для студентов форме изложены принципы  
и конструктивные особенности, а также режимы работы оптического, электронного и атомно-  
силового микроскопов.

Предназначено для студентов всех медицинских специальностей, изучающих медицинскую и  
биологическую физику на английском языке.

УДК 577.336 (075.8)  
ББК 28.707 (81.2 Англ-923)

ISBN 978-985-528-962-4

© Кухаренко Л. В., Недзьведь О. В., 2014  
© УО «Белорусский государственный  
медицинский университет», 2014

## INTRODUCTION

A microscope which is used to magnify, resolve and visualize a substance that is impossible to see by naked eyes, plays a vital role in various biological studies. There are several types of microscopes with varying magnification and resolving abilities operating in everyday biomedical research, from which three are more commonly used — an optical microscope, an electron microscope and an atomic force microscope.

This textbook provides a clear and comprehensive introduction to the field, describing in detail the basic principles of the optical microscope, the electron microscope and the atomic force microscope. Image formation by lenses, ray tracing rules in optical microscope, the optical principles involved in diffraction and microscope resolution are considered. The optical explanation of spherical and chromatic aberrations and the way in which they are corrected is presented in the textbook.

The components of modern electron microscope and atomic force one as well as the basic modes of their operation are discussed. Here advantages and as well as limitations of these microscopes, the way they are operated and the way they interact with the sample under investigation are considered. This textbook aimed to compare optical, electron, atomic force microscopes in relation to their use in biomedical research.

## PART 1 LENS OPTICS

The unaided eye can distinguish object details not smaller than 75 microns at a distance of the best vision. Special devices are used for the investigation of the microobjects. They allow to increase the image of the object ten, hundred and thousand times.

### 1.1. LENS OPTICS CHARACTERISTICS

The main part of optical instruments, a lens is used to form an image of an object by focusing rays of light from the object. Normally it is piece of glass or other transparent substance bounded on two sides by spherical surfaces. Each surface can be convex (bulging outwards from the lens), concave (depressed into the lens), or planar (flat). The line joining the centers of the spheres making up the lens surfaces is called the axis of the lens.

Lenses are classified by the curvature of the two optical surfaces. A lens is biconvex (or just convex) if both surfaces are convex. A lens with two concave surfaces is biconcave (or just concave). If one of the surfaces is flat, the lens is plano-convex or plano-concave depending on the curvature of the other surface. A lens with one convex and one concave side is convex-concave or meniscus. This type of lens is most commonly used in corrective lenses.

If the lens is convex or plano-convex, a parallel beam of light passing through the lens is focused to a point on the axis (this focal point is known as real focus), at a certain distance behind the lens. In this case the lens is called a converging lens. The distance from the lens to the focal point is the focal length of the lens, which is commonly abbreviated  $F$  in diagrams and equations.

If the lens is concave or plano-concave, a parallel beam of light passing through the lens is diverged; the lens is thus called a diverging lens. The beam after passing through the lens appears to be emanating from a particular point on the axis in front of the lens; the distance from this point to the lens is also known as the focal length, although it is negative in contrast to the focal length of a converging lens (fig. 1.1). Focal point for the diverging lens is called apparent or virtual focus.

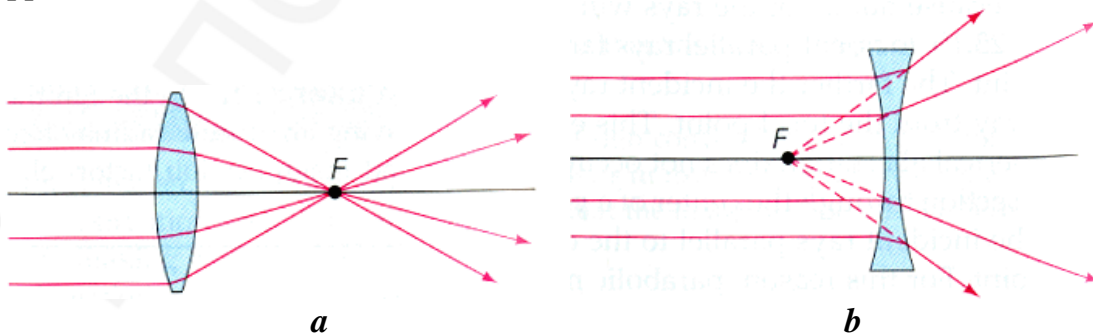

Fig. 1.1. *a* — converging lens; *b* — diverging lens

The properties of convex lenses: they converge rays; the focus of the lenses is real; they are thick in the center and thin at the edges. The properties of concave lenses: they diverge rays; the focus of the lenses is virtual; they are thin in the center and thick at the edges.

A thin lens is a lens with a negligible thickness (distance along the optical axis between the two surfaces of the lens) compared to the focal length of the lens.

The main characteristic of the lens is its optical power. Optical power is the degree to which a lens converges or diverges light. It is inversely proportional to the focal length of the lens:

$$D = \frac{1}{F}. \quad (1.1)$$

The shorter the focal length, the stronger the refraction in the lens and the larger the value of the optical power. For converging lenses the optical power is positive, while for diverging lenses it is negative. The most common unit of the optical power measurements is dioptre:

$$1 \text{ dioptre} = 1 \text{ m}^{-1}.$$

For two or more thin lenses close together, the optical power of the combined lenses is approximately equal to the sum of the optical powers of each lens:

$$D = D_1 + D_2. \quad (1.2)$$

The optical power of a lens *in air* can be calculated from the Lensmaker's equation:

$$D = (n - 1) \cdot \left( \frac{1}{R_1} - \frac{1}{R_2} \right) \quad (1.3)$$

where  $n$  is the refractive index of the lens material;  $R_1$  is the radius of curvature of the lens surface closest to the light source;  $R_2$  is the radius of curvature of the lens surface farthest from the light source (fig. 1.2).

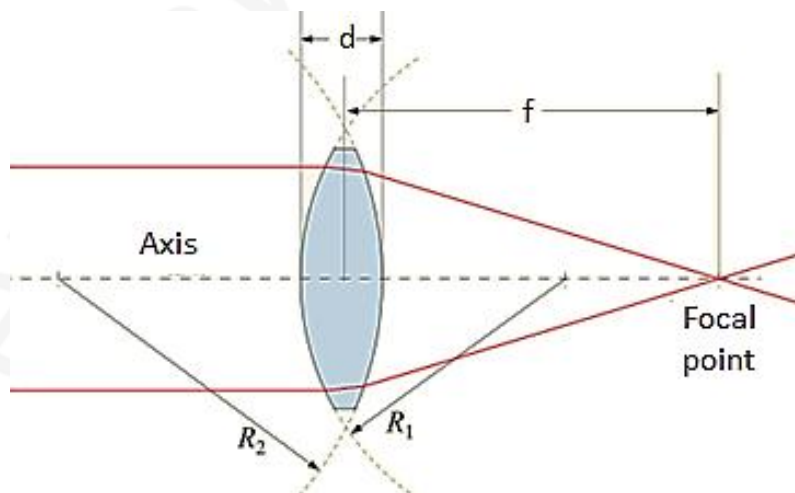

Fig. 1.2. Scheme of a converging lens

## 1.2. IMAGE FORMATION BY THIN LENSES

A converging lens in air focuses a parallel light beam travelling along the lens axis to a focal point at a distance  $F$  from the lens. Conversely, a point source of light placed at the focal point will be converted into a parallel beam by the lens. These two examples illustrate the image formation in lenses.

The image produced by a converging lens can be constructed using just three rays (fig. 1.3):

1. An incident ray which is parallel to the optic axis is refracted through the image focus of the lens.

2. An incident ray which passes through the object focus of the lens is refracted parallel to the optic axis.

3. An incident ray which passes through the optic center of the lens is not refracted at all.

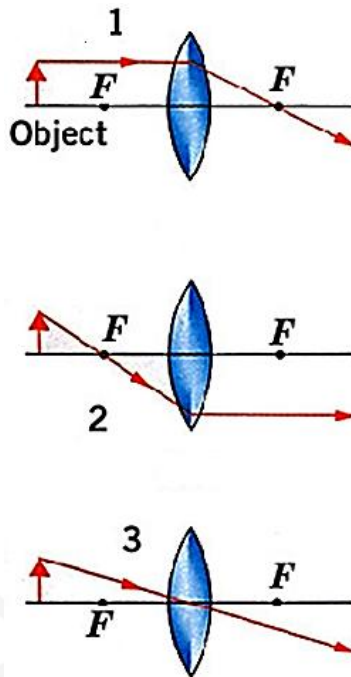

*Fig. 1.3. Principal rays for converging lenses*

If an object is placed at a distance greater than the focal length away from a converging lens, then it will form an inverted real image on the opposite side of the lens (fig. 1.4). The real image may be made visible on a screen.

Converging lenses form virtual images if the object distance is shorter than the focal length. This image is located on the same side of the lens as the object. Virtual image cannot be projected on a screen.

Diverging lenses form reduced, erect, virtual images. The image is always located between the object and the lens.

A real image is always formed on the side of the lens opposite to the object. A virtual image will appear to be on the same side of the lens as the object.

Ray Diagram	Characteristics of Image
<p>The object is between the lens and the focal point.</p> 	<ul style="list-style-type: none"> <li>• larger than object</li> <li>• farther from lens than object</li> <li>• upright</li> <li>• virtual</li> </ul>
<p>The object is between the focal point and twice the focal length.</p> 	<ul style="list-style-type: none"> <li>• larger than object</li> <li>• farther from lens than object</li> <li>• inverted</li> <li>• real</li> </ul>
<p>The object is more than twice as far from the lens as the focal point.</p> 	<ul style="list-style-type: none"> <li>• smaller than object</li> <li>• closer to lens than object</li> <li>• inverted</li> <li>• real</li> </ul>

Fig. 1.4. Characteristics of the images obtained by the converging lens

### 1.3. THIN LENS FORMULA

The thin lens equation relates the object distance, image distance and focal length. This equation is stated as follows:

$$\frac{1}{d} + \frac{1}{f} = \frac{1}{F}, \quad (1.4)$$

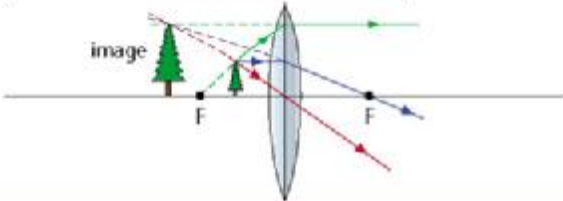
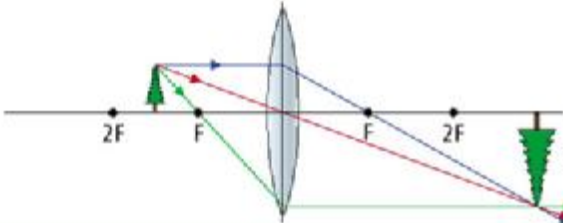
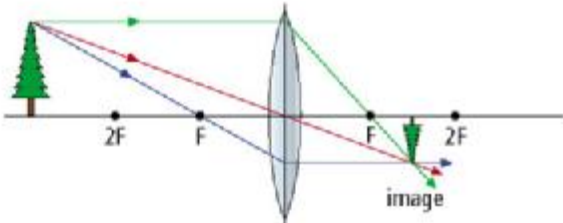
where  $d$  is the distance (measured along the axis) from the object to the center of the lens;  $f$  is the distance (measured along the axis) from the image to the center of the lens;  $F$  is the focal length of the lens.

When using this equation, signs are very important. Distance  $d$  from the object to the lens is always positive. Distance  $f$  from the image to the lens is positive for real images and negative for virtual ones. Focal length  $F$  is positive for converging lenses and negative for diverging ones.

### 1.4. THIN LENS MAGNIFICATION

The magnification of the lens is given by:

$$M = \frac{H}{h} = \frac{f}{d} = \frac{F}{d - F}, \quad (1.5)$$

where  $H$  is a size of an image;  $h$  is a size of an object.

Notice that, if  $M$  is negative, as it is for real images, the image is upside-down with respect to the object. For virtual images,  $M$  is positive and the image is upright.

## PART 2 OPTICAL ABERRATIONS

Lenses do not form perfect images. Lens errors or aberrations in optical microscopy are caused by artifacts arising from the interaction of light with glass lenses. In general, the effects of optical aberrations are to induce faults in the features of an image being observed through a microscope. There are two primary causes of aberration: geometrical or spherical aberrations are related to the spherical nature of the lens and chromatic aberrations that arise from variations in the refractive indices of the wide range of frequencies found in visible light.

### 2.1. SPHERICAL ABERRATION

Simple lenses suffer from the fact that light rays entering different parts of the lens have slightly different focal lengths. Spherical aberration causes beams parallel to, but distant from the lens axis to be focused in a slightly different place than beams close to the axis. This manifests itself as a blurring of the image (fig. 2.1).

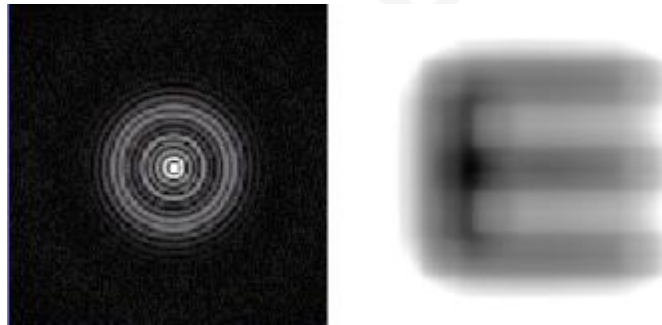

*Fig. 2.1.* Spherical aberration: causes halos around points of light

Spherical aberration can be minimized by using lens elements of different shapes to bring the more central and more peripheral rays to common focus (fig. 2.2).

Also the spherical aberration can be reduced by using a variable-aperture diaphragm (fig. 2.3). The pupil of the eye is an example of such a diaphragm.



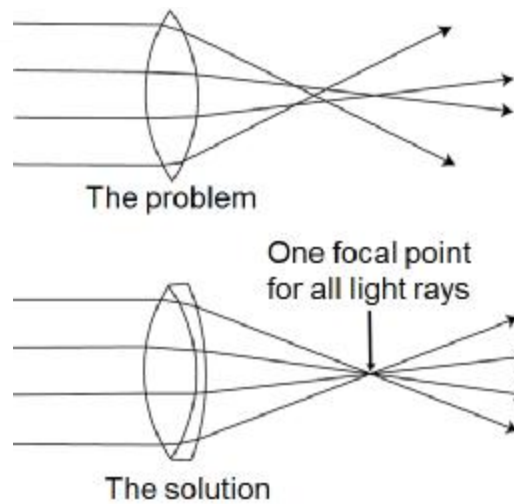

Fig. 2.2. Spherical aberration

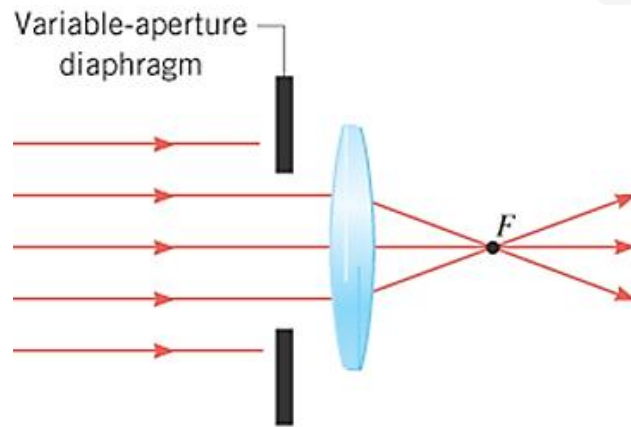

Fig. 2.3. Reduction of spherical aberration by using a variable-aperture diaphragm Spherical aberration

## 2.2. CHROMATIC ABERRATION

This type of optical defect is a result of the fact that white light is composed of numerous wavelengths. When white light passes through a convex lens, the component wavelengths are refracted according to their frequency. Blue light is refracted to the greatest extent followed by green and red light, a phenomenon commonly referred to as dispersion (fig. 2.4). The inability of the lens to bring all of the colors into a common focus results in a slightly different image size and focal point for each predominant wavelength group. This leads to color fringes surrounding the image.

It can be minimized by using an achromatic doublet (or *achromat*) in which two materials with differing dispersion are bonded together to form a single lens. This reduces the amount of chromatic aberration over a certain range of wavelengths, though it does not produce perfect correction (fig. 2.5).

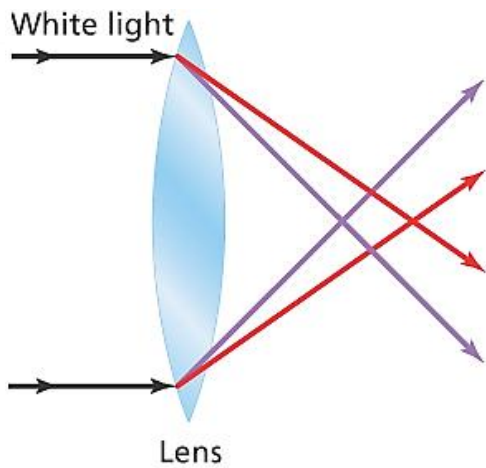

Fig. 2.4. Chromatic aberration

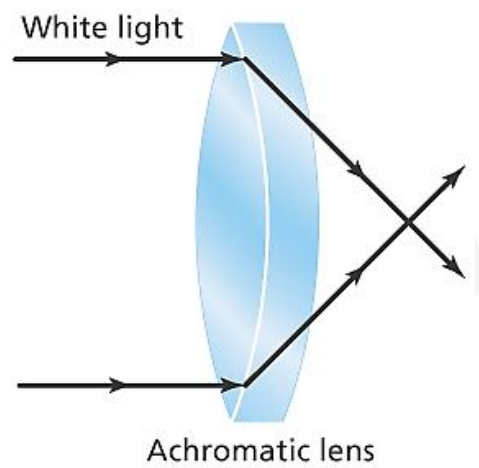

Fig. 2.5. Reduction of chromatic aberration by an achromatic lens

### PART 3 SIMPLE MAGNIFIER

The simple magnifier is a single converging lens used to increase the apparent size of an object. This lens has focal length from 1 cm to 12 cm. It is placed so that the object distance is less than the focal length. The virtual image formed is enlarged, upright, and farther away from the lens than the object (fig. 3.1).

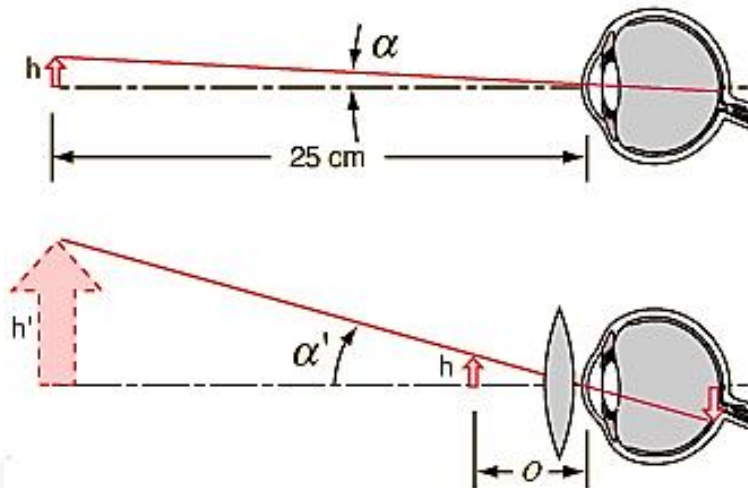

Fig. 3.1. Examination of a small object through a simple magnifier

A simple magnifier serves to make the image on the retina larger than it would be if viewed with the unaided eye by permitting the placement of the object closer to the eye than the eye could normally focus.

The angular magnification is the ratio of the angular size using the instrument to the angular size with the unaided eye. The standard close focus distance is taken as 25 cm, and the angular magnification is given by the relationships below:

$$M_{\alpha} = \frac{\alpha'}{\alpha}, \quad (3.1)$$

where  $\alpha_0$  is the angular size with the unaided eye;  $\alpha$  is the angular size using the simplifier.

The linear magnification of the magnifying glass is determined by formula:

$$M = \frac{h'}{h} = \frac{f}{d} \approx \frac{d_0}{F}, \quad (3.2),$$

where  $d_0$  is the distance of normal vision (usually equal to 25 cm);  $d$  is the distance from the object to the center of the lens;  $f$  is the distance from the image to the center of the lens;  $F$  is the focal length of the lens.

It may seem that a simple magnifier can be used for obtaining very large magnification when its focal length is short. For instance, the magnification of a magnifying glass with a focal length of 0,25 mm should be 1000. However, it is practically impossible to employ simple magnifiers with very short focal lengths, and hence with very small diameters due to aberrations. So magnifying glasses with a magnification exceeding 40 are not used.

## PART 4 OPTICAL MICROSCOPY

### 4.1. FUNDAMENTALS OF AN OPTICAL MICROSCOPE

A compound light microscope is an optical instrument that uses visible light to produce a magnified image of an objects (that are too small to be seen with the naked or unaided eye) that is projected onto the retina of the eye or onto an imaging device.

The main components of optical microscope are an objective lens and an eyepiece (ocular) one (fig. 4.1). Light microscope uses a beam of light to create an enlarged image of the specimen.

The objective (convergent lens) is a lens with very short focal length. The eyepiece or ocular (convergent lens) is a lens with a focal length of a few centimeters. The objective lens forms a real, inverted and magnified image  $A_1B_1$  of the object  $AB$ , which is placed in front of the focal point of the objective  $F_1$ . This real image  $A_1B_1$  located between the eyepiece focal point  $F_2$  and the eyepiece serves as an object for the eyepiece, which produces a *magnified, virtual, inverted image*  $A_2B_2$ . Thus the observer looking through the eyepiece sees the *magnified, virtual, inverted image*  $A_2B_2$  (fig. 4.2).

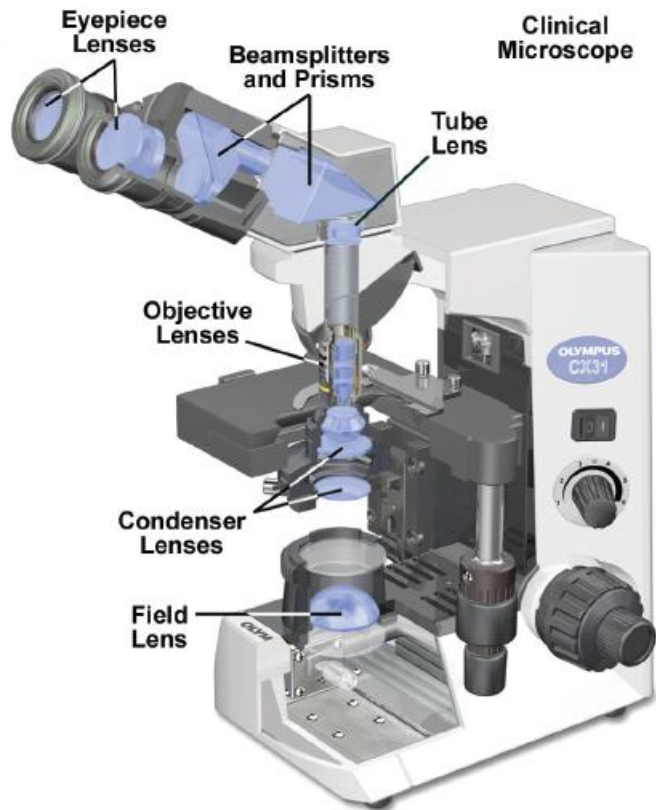

Fig. 4.1. A modern clinical microscope with mechanical stage and binocular head

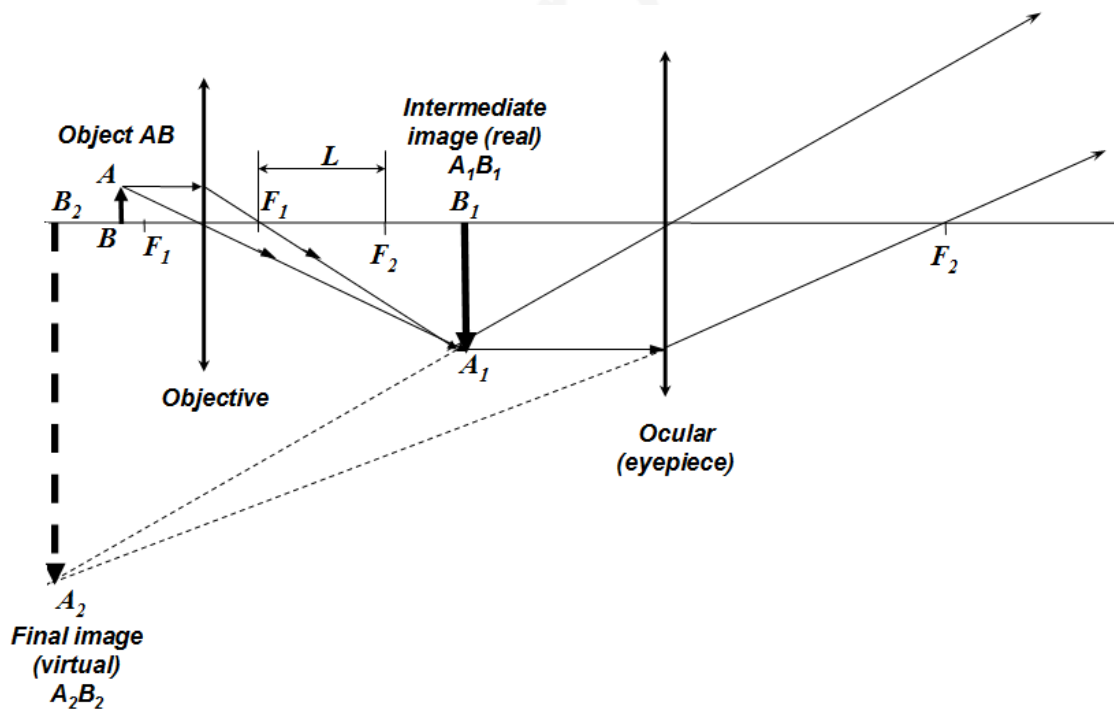

Fig. 4.2. Ray tracings in the optical microscope:

$F_1$  and  $F_2$  are the respective objective and eyepiece focal points;  $AB$  is an object,  $A_1B_1$  is a real image of the object formed by the objective,  $A_2B_2$  is a virtual image seen in

the eyepiece;  $L$  is an optical interval of the microscope

Microscope magnification  $M_m$  shows how much an image is enlarged:

$$M_m = \frac{A_2B_2}{AB}, \quad (4.1),$$

where  $AB$  is the object's size and  $A_2B_2$  is the image size. The total magnification of the compound microscope is defined as the product of magnifications of the objective lens  $M_{ob}$  and the ocular lens  $M_e$ :

$$M_m = M_{ob} \cdot M_e. \quad (4.2)$$

The magnification by the objective is the ratio of an optical interval of the microscope (distance between focal point  $F_1$  and focal point  $F_2$ )  $L$  to the objective focal distance (distance between center of objective lens and focal point  $F_1$ )  $f_1$ :

$$M_{ob} = \frac{L}{f_1}. \quad (4.3)$$

The magnification by the eyepiece for an object is the ratio of the distance of best vision (distance of the most distinct vision (0,25 m)  $d$  to the eyepiece focal distance (distance between center of eyepiece lens and focal point  $F_2$ )  $f_2$ :

$$M_e = \frac{d}{f_2}. \quad (4.4)$$

Thus the total magnification of the optical microscope is defined as the product of magnifications:

$$M_m = \frac{d \cdot L}{f_2 \cdot f_1}. \quad (4.5)$$

So for 10X objective magnification and 10X ocular one, total magnification equals  $10 \times 10 = 100X$  (this means that the image being viewed will appear to be 100 times its actual size). For a 40X objective and 10X ocular, total magnification equals  $10 \times 40 = 400X$ .

The ability of an optical microscope to view an object depends on the size of the object relative to the wavelength of the light used to observe it. Sizes of small details that can be discerned through a microscope depend on the restrictions due to light diffraction. Diffraction is a deviation of light from the rectilinear propagation as it passes around the edge of an object that is physically the approximate size of, or even smaller than that light's wavelength.

## 4.2. RESOLUTION AND RESOLUTION LIMIT

Resolution is defined as the ability of a microscope to separate clearly two points or details lying close together in the specimen. Resolution is best when the distance separating the two tiny points is small (fig. 4.3).

The main characteristic of the microscope resolution is resolution limit. **Resolution limit  $Z$**  of the microscope is the smallest distance between two

points on the object that can still be distinguished by the observer as two separate entities (fig. 4.4). Resolution is the reciprocal of the limit of resolution.

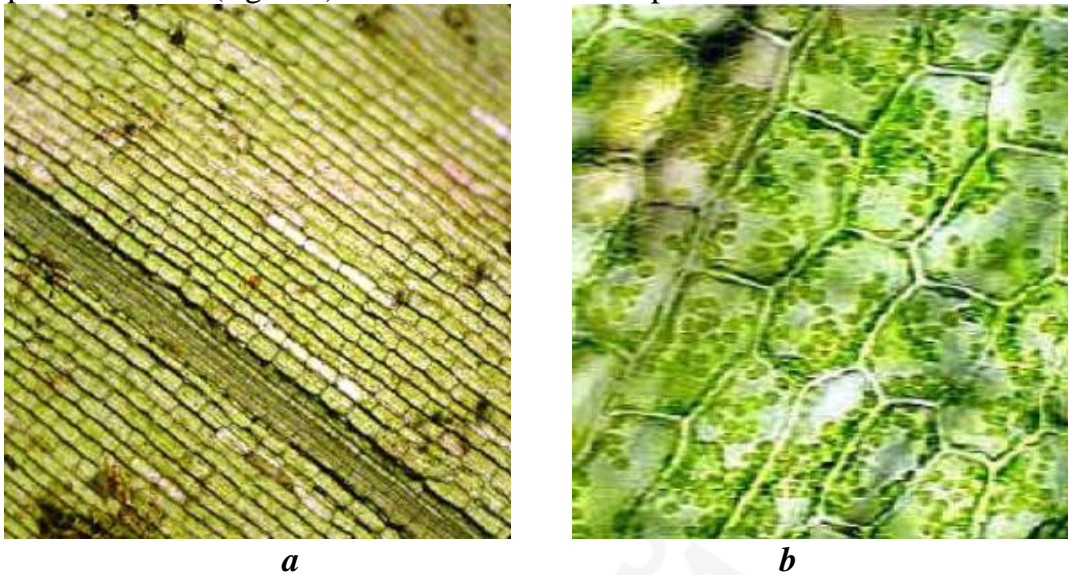

Fig. 4.3. Images obtained with low resolution (*a*) and high resolution (*b*)

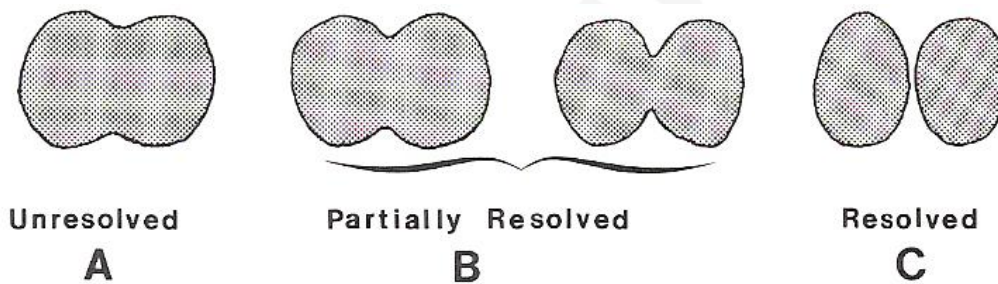

Fig. 4.4. Illustration of resolution of two objects. As the resolution of these two objects improves ( $A \rightarrow B \rightarrow C$ ), the objects can be distinguished by the observer as two separate entities

The German physicist Ernst Abbe has realized that the resolution of optical imaging instruments, including telescopes and microscopes, is fundamentally limited by the diffraction of light. According to Abbe's equation for resolution limit for the linear form objects is:

$$Z = \frac{0,5\lambda}{n \sin\alpha}, \quad (4.6)$$

and for rounded objects is:

$$Z = \frac{0,61\lambda}{n \sin\alpha}, \quad (4.7)$$

where  $\lambda$  is the wavelength of light being used;  $n \sin\alpha$  is the numerical aperture ( $NA$ ) of the objective.

In the numerical aperture  $n$  represents the refractive index of the medium between the objective front lens and the specimen, and  $\alpha$  is the one-half angular

aperture of the objective. Aperture angle is the angle between the extreme rays of the light beam, which enters in the lens from the object. This angle will depend on the curvature of the lens and also on how close the objective lens is to the specimen when it is in focus. The numerical aperture of a microscope objective is a measure of its ability to gather light and resolve fine specimen detail at a fixed object distance. Image-forming light waves pass through the specimen and enter the objective in an inverted cone as illustrated in fig. 4.5.

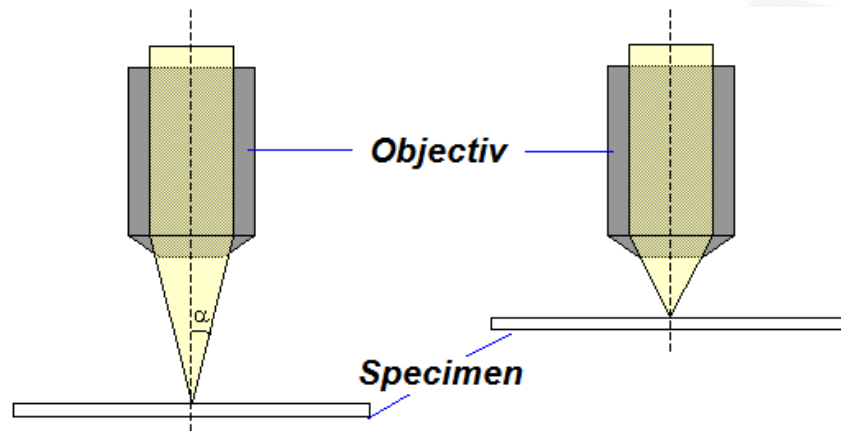

Fig. 4.5. Aperture angle is the angle between the extreme rays of the light beam, which enters in the lens from the object.  $\alpha$  is the one-half angular aperture of the objective

Analysis of Abbe's equation will lead to the following inferences: as  $NA$  increases resolution limit  $Z$  becomes smaller, that is the size of the distance between adjacent points becomes smaller and hence resolution is better.

Modern microscopes with dry objectives ( $n = 1$ ) have large enough aperture angle exceeding 70 to 80 degrees ( $\sin 70^\circ = 0,94 \approx 1$ ), therefore the limit of resolution is approximately equal to half the wavelength of light ( $Z \approx 0,5\lambda$ ) being used. Light microscopes use visible light (which has a minimum wavelength of 400 nm). This means that one will never be able to see any object smaller than approximately 200 nm (about the width of an average-sized bacterium) using a light microscope.

In practice, it is difficult to achieve numerical aperture values above 0.95 with dry objectives. Higher numerical apertures can be obtained by increasing the imaging medium refractive index ( $n$ ) between the specimen and the objective front lens (fig. 4.6). In some microscopes (*immersion microscopes*) to reduce the limit of resolution the space between the lens and the subject can be filled with water (refractive index  $n = 1.33$ ), glycerin (refractive index  $n = 1.47$ ), and immersion oil (refractive index  $n = 1.51$ ). So, for an objective with an aperture angle of  $120^\circ$  with air between specimen and objective lens,  $NA = 1 \cdot \sin 60^\circ = \sin 60^\circ = 0.87$ . If oil with refractive index of 1.5 is used between the objective lens and the specimen,  $NA = 1.5 \cdot \sin 60^\circ = 1.5 (0.87) = 1.31$ .

So, for air situation,  $Z = 0.5 \cdot 400 \text{ nm} / 0.87 = 230 \text{ nm}$ .

For oil immersion,  $Z = 0.5 \cdot 400 \text{ nm} / 1.31 = 153 \text{ nm}$ .

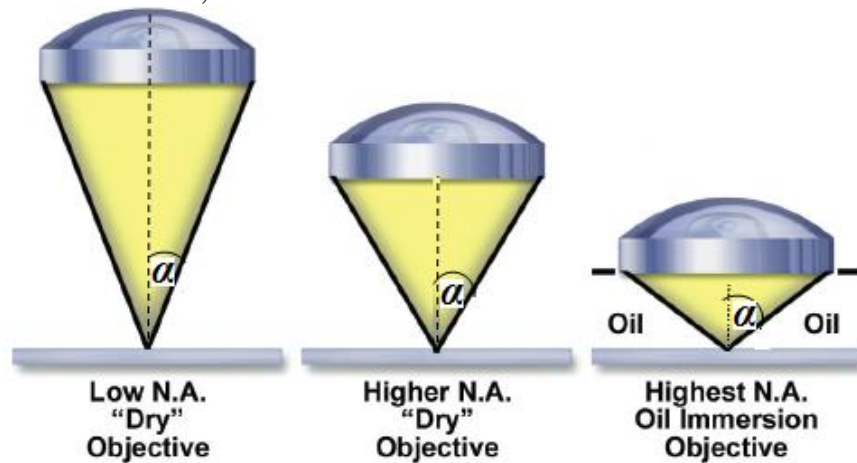

Fig. 4.6. Methods of the numerical aperture (NA) changing

At full aperture and with good oil immersion lenses it is possible to be able to resolve slightly better than 200 nm. A majority of objectives in the magnification range between **60x** and **100x** (and higher) are designed for use with immersion oil.

Another way of optical resolution increasing is to use shorter wavelengths  $\lambda$  of light being used to illuminate the specimen. If shorter wavelengths  $\lambda$  of light are used (e. g. violet-blue end of the spectrum) the resolvable distance becomes smaller and resolution is better. Shorter wavelengths are capable of resolving details to a greater degree than are the longer wavelengths. Longer wavelengths (e. g. red) yield poorer resolution. To increase the resolution, shorter wavelengths can be used such as UV and X-ray microscopes. However, it is practically impossible to make a lens which can focus X-rays effectively, making an X-ray microscope is still a challenge for scientists and engineers.

## PART 5 ELECTRON MICROSCOPY

### 5.1. FUNDAMENTALS OF AN ELECTRON MICROSCOPE

In the 1920s, it was discovered that accelerated electrons behave in vacuum much like light. They travel in straight lines and have wavelike properties, with a wavelength that is about 100.000 times shorter than that of visible light. Furthermore, it was found that electric and magnetic fields could be used to shape the paths followed by electrons similar to the way glass lenses are used to bend and focus visible light. Ernst Ruska at the University of Berlin combined these characteristics and built the first transmission electron microscope (TEM) in 1931.



The wave particle duality concept of quantum physics asserts that all matter exhibits both wave-like and particle-like properties. By combining some of the principles of classical physics with the quantum theory, De Broglie proposed that moving particles (with mass  $m$  and velocity  $v$ ) have wave-like properties and their wavelength can be calculated as

$$\lambda_{Br} = \frac{h}{p} = \frac{h}{mv}, \quad (5.1)$$

where  $h$  is Plank's constant and  $p$  is the relativistic momentum of the particle.

When an electron (with charge  $e$ ) passes through a potential difference  $U$  (acceleration voltage field), its kinetic energy will be equal to the energy of the field, i. e.:

$$\frac{1}{2}mv^2 = eU. \quad (5.2)$$

Knowing the rest mass of an electron  $m$ , and its charge  $e$ , one can calculate the velocity  $v$  imparted by an electric potential  $U$  as:

$$v = \sqrt{\frac{2eU}{m}}, \quad (5.3)$$

and electron wavelength at that velocity as:

$$\lambda_{Br} = \frac{h}{p} = \frac{h}{mv} = \frac{h}{\sqrt{2meU}}. \quad (5.4)$$

The higher the accelerating voltage  $U$  between cathode and anode, the less electron wavelength  $\lambda$ . The wavelength  $\lambda$  of the electrons in scanning electron microscope with the acceleration voltage  $U = 10 \text{ kV}$  is then  $12.3 \times 10^{-12} \text{ m} = 12.3 \text{ pm}$ , while in a 200 kV transmission electron microscope the wavelength  $\lambda$  is 2.5 pm. The wavelength of electron beam is much more shorter than light, resulting in much higher resolution (fig. 5.1).

Electron microscopes follow the same ideas of optical microscopes except that they use a focused beam of electrons instead of light to "image" the specimen and gain information as to its structure and composition. There are two basic types of electron microscopes — scanning electron microscope (SEM) and transmission electron microscope (TEM). In scanning electron microscope an electron beam focused into a small probe scans the surface of the specimen and the electrons released by the beam-specimen interaction are collected and evaluated which allows the generation of the surface features. In transmission electron microscope specimen is a very thin section of tissue that allows the electrons to be largely transmitted through the tissue. Cross section of the column of a modern transmission electron microscope is shown in fig. 5.2.

The electron column includes elements analogous to those of a light microscope. The light source of the light microscope is replaced by an electron gun, which is built into the column. The glass lenses are replaced by

electromagnetic lenses. Unlike glass lenses, the power (focal length) of magnetic lenses can be changed by changing the current through the lens coil. In the light microscope, variation in magnification is obtained by changing the lens or by mechanically moving the lens. The eyepiece or ocular is replaced by a fluorescent screen and/or a digital camera. In transmission electron microscope a stream of electrons emerges from the electron gun (usually at the top of the column). This stream is accelerated towards the specimen (with a positive electrical potential) while is condensed into a nearly parallel beam at the specimen by the condenser lenses. The specimen must be thin enough to transmit the electrons, typically  $0.5 \mu\text{m}$  or less. Higher energy electrons (i. e., higher accelerating voltages) can penetrate thicker samples. The sample is irradiated by the beam and interactions occur inside the irradiated sample, affecting the electron beam. After passing through the specimen, transmitted electrons are collected and focused by the objective lens and a magnified real image of the specimen is projected by the projection lens onto the viewing device at the bottom of the column. The entire electron path from gun to camera must be under vacuum (otherwise the electrons would collide with air molecules and be scattered or absorbed, and electron source (tungsten) would blow).

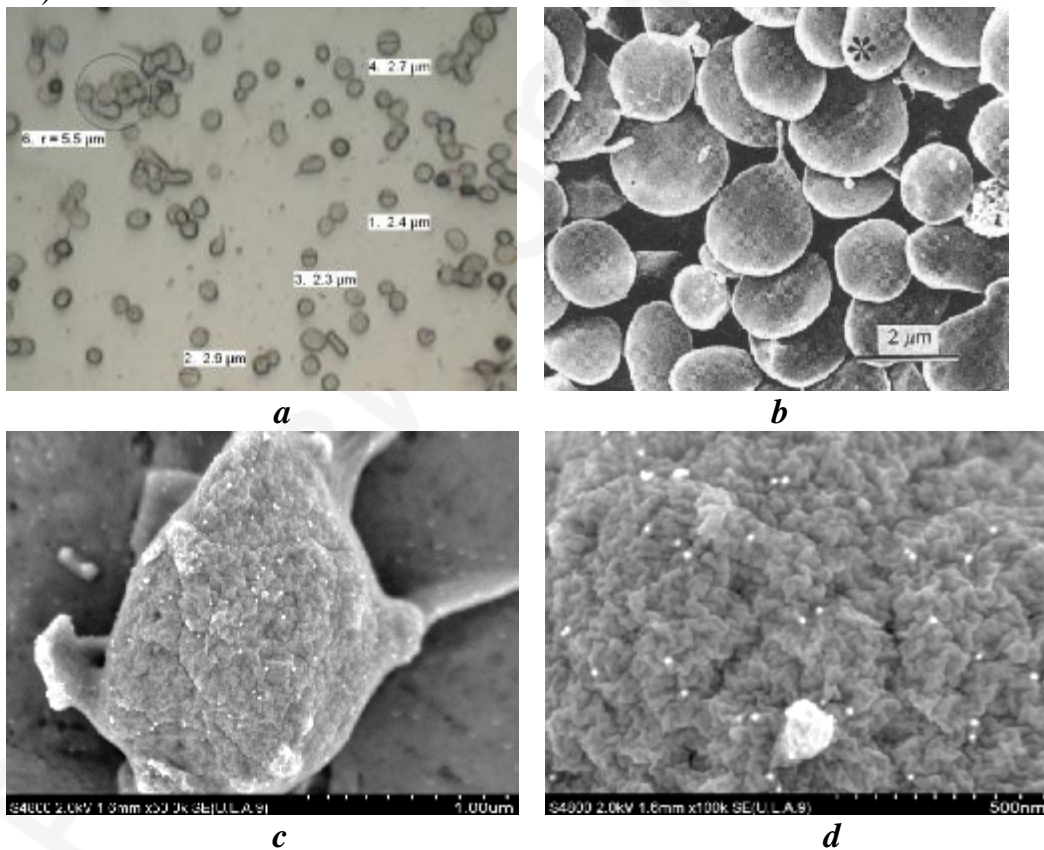
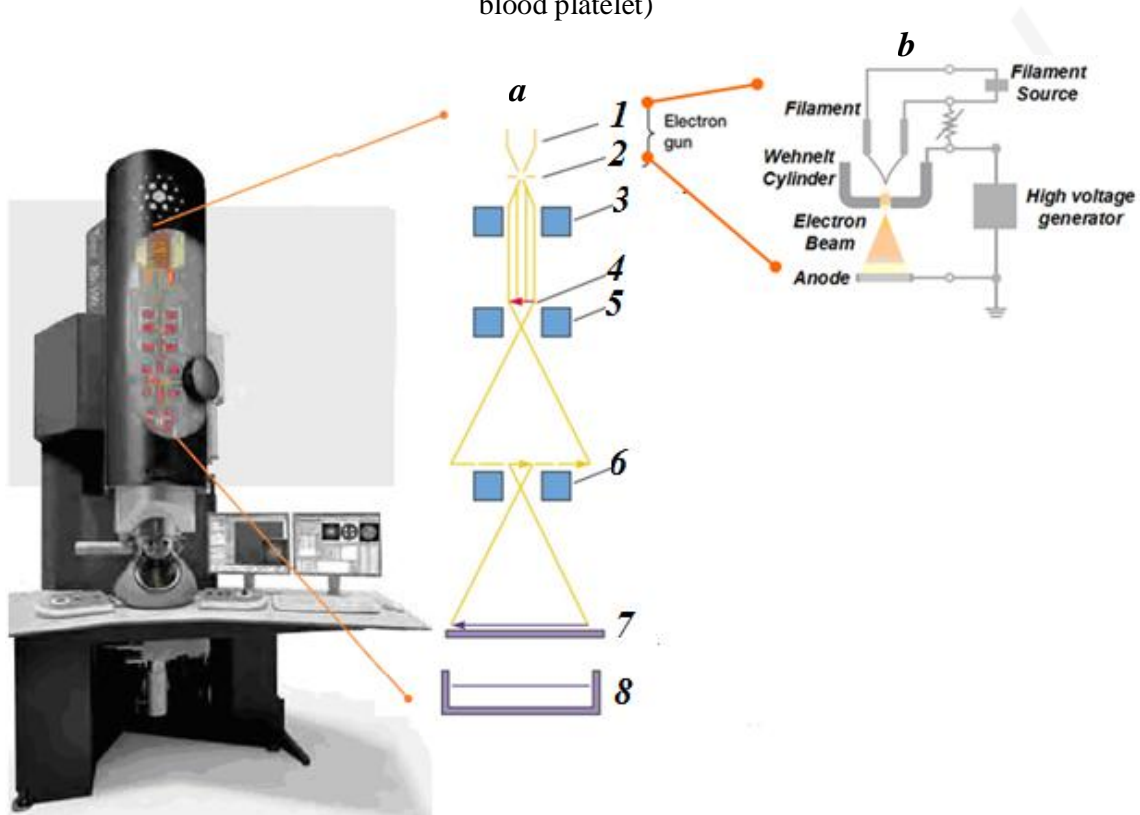

Fig. 5.1. *a* — image of human platelets obtained by optical microscope (100X); *b* — image of human platelets obtained by scanning electron microscope; *c* — image of human platelet

obtained by scanning electron microscope; *d* — image of platelet membrane allows to understand the distribution of specific proteins on cell surface (the beta 3 antigen has reacted with antibodies that are marked by 10 nm colloidal gold particles on an activated human blood platelet)



*Fig. 5.2. a* — cross section of the column of a modern transmission electron microscope: 1 — filament (cathode); 2 — anode; 3 — condenser lens magnet; 4 — specimen; 5 — objective lens magnet; 6 — projector lens magnet; 7 — final image on fluorescent screen; 8 — final image on photographic film when screen is lifted aside;

*b* — schematic cross section of the electron gun in an electron microscope

Fig. 5.2 also demonstrates schematic cross section of the electron gun in an electron microscope. Three main types of electron sources are used in electron microscopes: tungsten, lanthanum hexaboride (LaB6 — often called “lab six”), and field emission gun (FEG). A tungsten gun comprises a filament (cathode), a Wehnelt cylinder, and an anode. These three together form a triode gun, which is a very stable source of electrons. The tungsten filament is hairpin-shaped and heated to about 2700 °C. By applying a high positive potential difference between the filament (cathode) and the anode, thermally excited electrons are extracted from the electron cloud near the filament and accelerated towards the anode. The anode has a hole in it so that an electron beam, in which the electrons may travel faster than two thousand kilometers per second, emerges and is directed down the column. The Wehnelt cylinder, which is held at a variable potential slightly negative to the filament, directs

the electrons through a narrow cross-over to improve the current density and brightness of the beam.

The most important differences between TEM and SEM are:

- rather than the broad static beam used in TEM, the SEM beam is focused to a fine point and scanned line by line over the sample surface in a rectangular raster pattern;

- the accelerating voltages are much lower than in TEM because it is no longer necessary to penetrate the specimen; in a SEM they range from 50 to 30,000 Volts;

- the specimen need not be thin, greatly simplifying specimen preparation.

In SEM once the electron beam hits on the sample surface, electrons (secondary electrons and backscattered electrons) and X-rays are emitted. These emissions are detected and analyzed in order to put the material picture on the screen. Secondary electrons, because of their very low energies, can escape the sample to be detected only if they originate very close to the sample surface. This gives secondary electrons images high spatial resolution and strong topographic contrast. The backscattered electrons signal is used primarily for its strong atomic number contrast. Characteristic X-rays are also widely used in SEM for elemental microanalysis.

Resolution limit  $Z_{\text{elect.microscope}}$  of the electron microscope is given by formula:

$$Z_{\text{elect.microscope}} = \frac{0,5\lambda_{Br}}{A} = \frac{h}{2A\sqrt{2emU}}, \quad (5.5)$$

where  $A$  is the numerical aperture of a electron microscope;  $h$  is the Planck constant;  $m$  is the electron rest mass;  $e$  is the electron charge;  $U$  is the acceleration voltage applied between anode and cathode of electron gun.

As follows from this equation when acceleration voltage of electrons  $U$  between cathode and anode increases, the resolution limit of electron microscope becomes smaller. The shorter wavelength of electron, the greater resolution of electron microscope. In transmission electron microscopes acceleration voltage of electrons reaches 200 kV and the resolution limit is about 0.1 nm. The resolution limit of scanning electron microscopes varies from 1 nm to 20 nm. Resolution in a SEM also depends on the size of the spot formed by the electron beam.

While SEM is operated in a vacuum and also uses electrons in the imaging process, special events should be followed in sample preparation. The biological materials to be viewed in an electron microscope generally require a special fixation. The only requirement is that the specimen must be able to withstand the vacuum of the chamber and bombardment by the electron

beam. For transmission electron microscope investigations, for example, there may be first a chemical treatment to remove water and preserve the tissue as much as possible in its original state, followed by embedding in a hardening resin; after the resin has hardened, slices (sections) with an average thickness of 0.5  $\mu\text{m}$  are cut with an instrument called an ultramicrotome equipped with a glass or diamond knife. The tiny sections thus obtained are placed on a specimen carrier. In chemical fixation for electron microscopy, glutaraldehyde is often used to crosslink protein molecules and osmium tetroxide to preserve lipids. The preparation of specimens to be investigated by SEM is considerably simpler than the preparation of specimens for TEM. To increase the scattering of electrons in the specimen, salts or oxides of heavy metals (osmium, tungsten, uranium) are used. Biological specimens have to be dried at low temperature in  $\text{CO}_2$  atmosphere. Non-conducting biomedical materials have to be coated by thin metal layer (Au, C, Ag — vaporised metals are applied). Cryo-preparations are also used in SEM, particularly in biological applications or organic materials (polymers).

## **PART 6**

### **ATOMIC FORCE MICROSCOPY**

#### **6.1. FUNDAMENTALS OF AN ATOMIC FORCE MICROSCOPE**

AFM is a high resolution imaging technique that can resolve features as small as an atomic lattice in the real space. It allows researchers to observe and manipulate molecular and atomic level features.

In AFM, the tip mounted on a flexible force-sensing cantilever is brought into gentle contact with the sample surface. By actuating the piezoelectric scanner, the tip is raster scanning the sample surface. The force acting between the tip and the sample causes minute deflections (bending) of the cantilever. The deflections are detected by optical system and utilized as feedback signal. By keeping the interaction force between the tip and the sample constant, a topographic image of the surface sample is obtained. A schematic representation of the components of an AFM is shown in fig. 6.1.

A typical AFM consists of a cantilever with a small tip at the free end, an optical system (a laser, a 4-quadrant photodiode), a piezoelectric scanner and feedback loop.

The force sensor of AFM consists of a cantilever with a sharp tip (probe) at one end. The topography of a sample is obtained by measuring and modulating the interaction forces between the tip and the sample. In order to achieve sufficient sensitivity for atomic resolution, the cantilever has to satisfy several requirements. The cantilever must be flexible yet resilient, with a spring constant which is small enough. Therefore, a change of interaction force of a small fraction of a nanonewton (nN) can be detected. For atomic resolution

AFM studies a sharp protruding tip must be formed at the end of the cantilever to provide a well-defined interaction with the sample surface, presumably with a single atom at the apex. Most AFM cantilevers used today are microfabricated from silicon oxide, silicon nitride or pure silicon. There are a microscale rectangular or “V”-shaped cantilever (fig. 6.2). For microfabricated cantilevers the typical length is 50–200  $\mu\text{m}$  and width — 5–50  $\mu\text{m}$ .

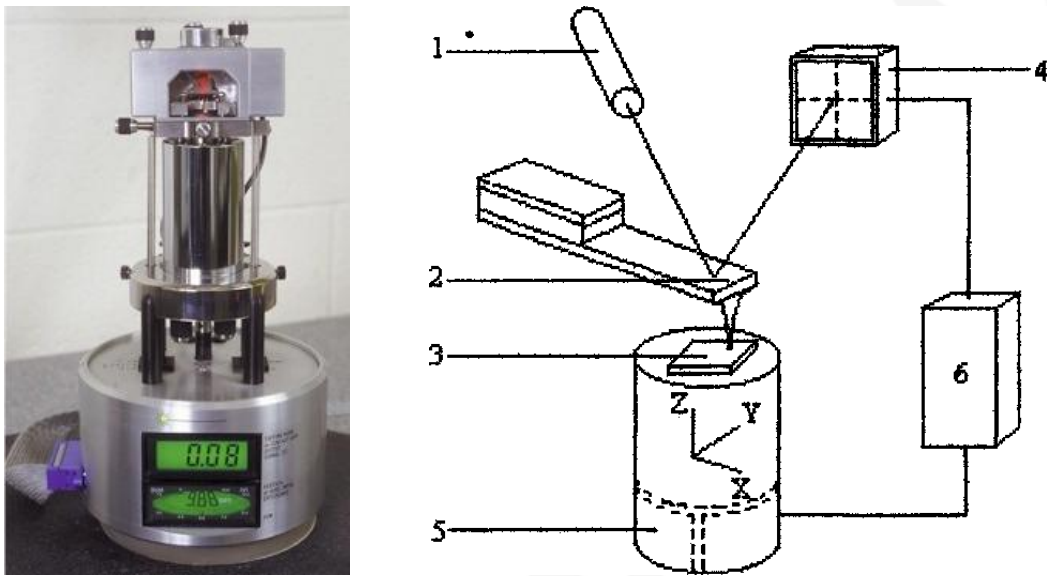

Fig. 6.1. AFM and a schematic representation of the components of the AFM: 1 — a laser; 2 — a cantilever; 3 — a sample; 4 — a four-quadrant photodiode; 5 — a piezoelectric scanner; 6 — a feedback loop

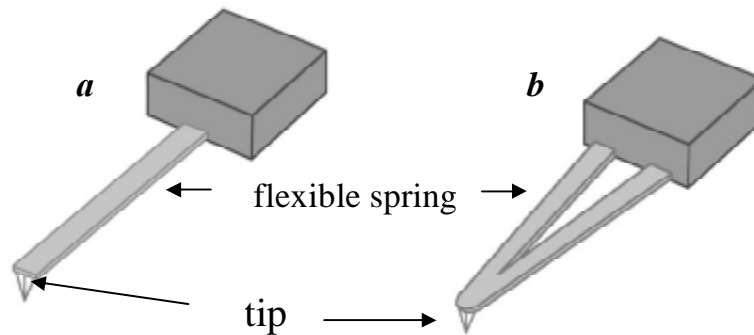

Fig. 6.2. Microscale rectangular (a) and “V”-shaped (b) cantilevers

Curvature radius of tip varies from 2 nm to 20 nm (fig. 6.3), depending on tip type, and potentially can be as small as 0.5 nm for a single carbon nanotube.

Most AFM used nowadays are based on optical detection method for sensing the small cantilever displacement. The laser beam is reflected by top surface of cantilever (fig. 6.4). The deflection of the cantilever deflects the laser beam, thus changing the proportion of light falling on position sensitive

4-quadrant photodiode. The difference of the signals from four parts of the photodiode is detected. Using this position sensitive photodiode the cantilever bending can be measured very precisely.

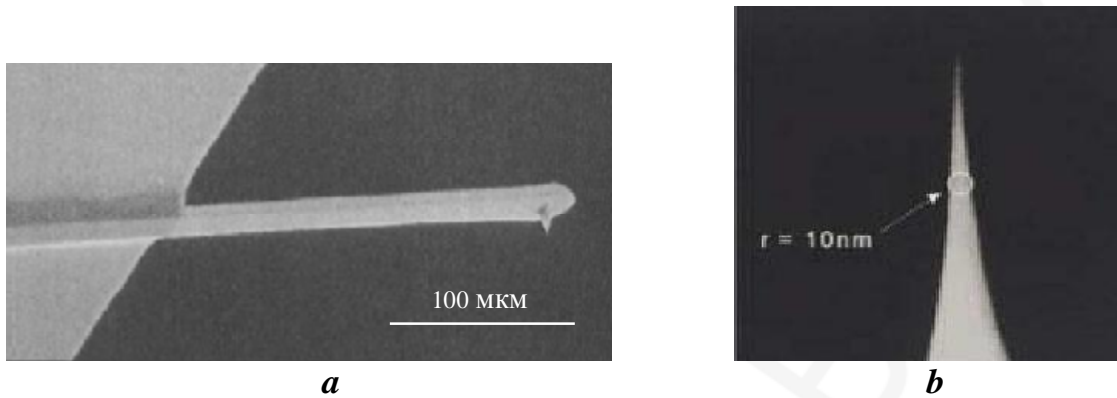

Fig. 6.3. Micrographs of cantilever (a) and tip (b) obtained by scanning electron microscope

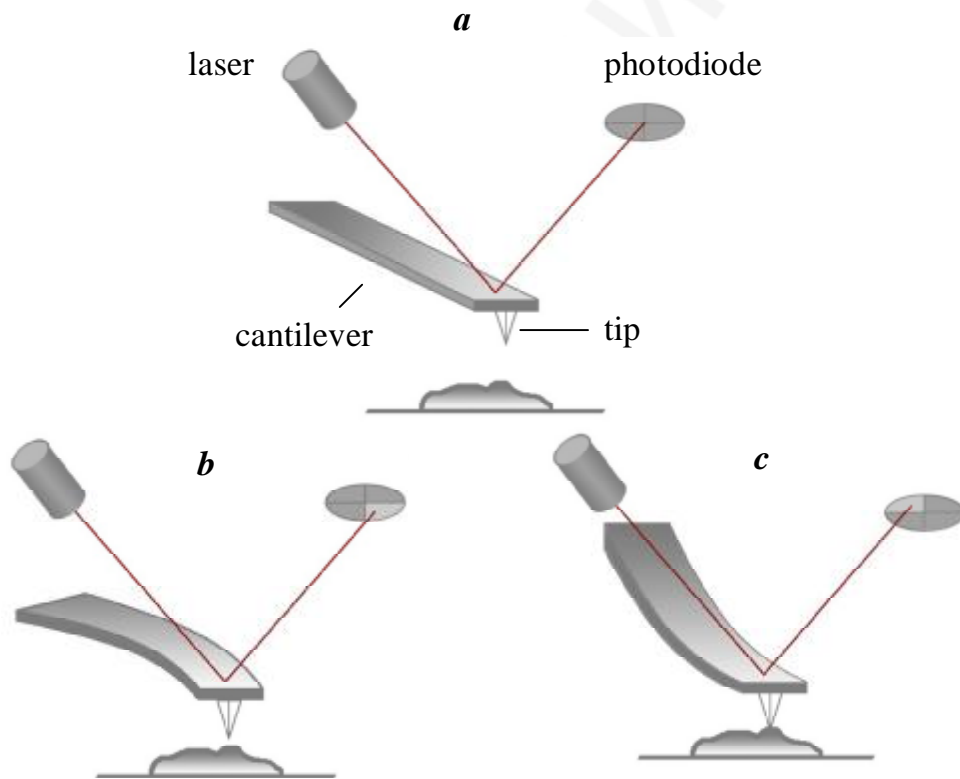

Fig. 6.4. Detection of cantilever deflection by optical beam deflection:  
*a* — an equilibrium position; *b* — action of the attractive force; *c* — action of the repulsive force

The piezoelectric scanner provides a way of controlling the tip-sample distance and moving the tip over the surface. The piezoelectric scanner is made

of piezoelectric ceramic which changes its geometry when a voltage is applied; the voltage applied is proportional to the resulting mechanical movement. The piezoelectric effect underlies the piezoelectric scanner operation. There is direct and reverse (or indirect) piezoelectric effect. The piezoelectric effect is direct when electric voltage is generated as a result of the mechanical stress of certain piezoelectric materials (such as quartz crystals and ceramics). The piezoelectric effect is reverse when expansion or contraction of piezoelectric materials is generated due to the application of a voltage. The piezoelectric scanner in an AFM is designed to bend, expand, and contract in a controlled, predictable manner. The sample (or tip) is assembled on a piezoelectric scanner that besides enabling the scanning through the displacement of the sample on the  $xy$  plan is responsible for the movement on the  $z$  axis.

The principle of AFM operation is to scan the tip over the sample surface with feedback mechanisms that enable the piezoelectric scanner to maintain the tip at a constant force, or constant height above the sample surface. As the tip scans the surface of the sample, moving up and down with the contour of the surface, the laser beam deflected from the cantilever provides measurements of the difference in light intensities between the upper and lower photodetectors. Feedback from the photodiode difference signal, through software control from the computer, enables the tip to maintain either a constant force or constant height above the sample.

## 6.2. FORCE INTERACTION BETWEEN TIP AND SAMPLE

In general, the dependence of the interaction force  $F$  on distance  $r$  between the atoms is described by:

$$F(r) = -\frac{a}{r^m} + \frac{b}{r^n}. \quad (6.1)$$

Constants  $a$  and  $b$  as well as the exponents  $m$  and  $n$  depend on the type of interacting atoms and type of chemical bonds.

The dependence of the interaction force  $F$  on distance  $r$  between the atoms of the tip and those of the sample is shown in fig. 6.5.



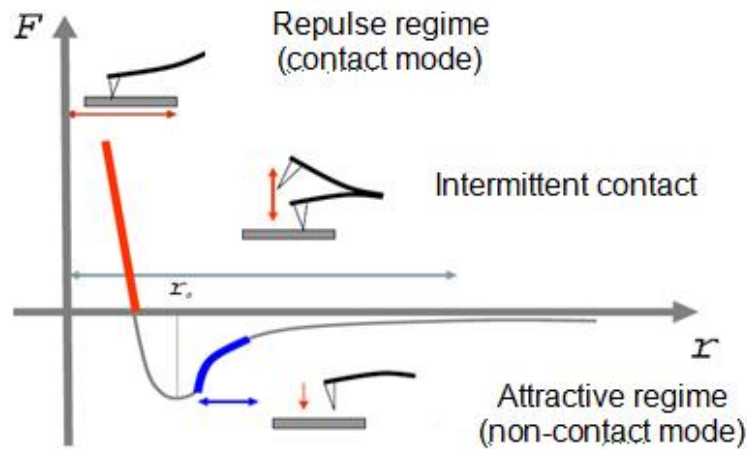

Fig. 6.5. The dependence of the interaction force  $F$  on distance  $r$  between the atoms of the tip and those of the sample

Atomic forces between a tip and a sample are electromagnetic ones. The repulsive force is considered to be positive while the attractive force — negative. Attractive and repulsive forces rapidly decrease as distance  $r$  between the atoms of the tip and those of the sample surface increases. The atomic forces of interaction are short-range forces. As the tip approaches towards the sample surface, the cantilever bends towards the sample due to attractive force (at distance  $r > r_0$ ). Attractive and repulsive forces balance each other at the tip-sample distance  $r_0$ . This equilibrium distance  $r_0$  is about 0.3 nm. With a further tip approaches towards the sample surface (the tip-sample distance is less than  $r_0$  ( $r < r_0$ )) electron clouds of tip atoms and sample ones begin to overlap and to repel each other, which leads to a repulsive force between the tip and the sample surface. The repulsive forces decay rapidly with increasing tip-sample surface separation.

### 6.3. MODES OF AFM OPERATION

The three general types of AFM imaging are contact mode, intermittent mode and noncontact mode. In **contact mode**, the tip is in continuous gentle contact with the surface sample to be analyzed, and set to scan the sample in a  $x$ - $y$  raster pattern (fig. 6.6).

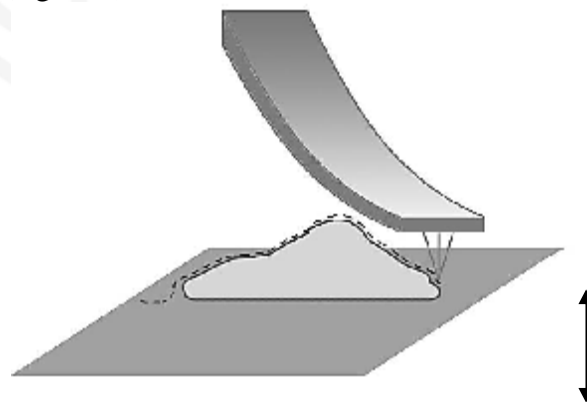

Fig. 6.6. Schematic diagram of contact mode AFM operation

The condition of constant interaction force is achieved by keeping the cantilever deflection constant by means of a feedback circuit. While rastering the tip goes through the repulsive (contact situation) regions of the tip-sample interaction force. Measured force varies from  $10^{-4}$  to  $10^{-8}$  N.

The most common AFM mode for imaging biological samples is intermittent contact, the latter also called tapping or dynamic mode. In the case of **tapping mode**, the cantilever is oscillated at a frequency near its resonance and the oscillation amplitude is measured (fig. 6.7). While rastering the sample in  $x$ - $y$ , the AFM tip briefly touches the sample at the bottom of each swing, producing a decrease in the oscillation amplitude. The tip goes through both the attractive (noncontact situation) and the repulsive (contact situation) regions of the tip-sample force interaction during the oscillations. Tip-sample interactions give rise to changes in tip oscillation phase and amplitude producing phase and topography images, respectively. During tapping mode operation, the cantilever oscillation amplitude is maintained constant by a feedback loop and is measured by the detector, the digital feedback loop then adjusts the tip-sample separation to maintain constant the amplitude and the applied force on the sample.

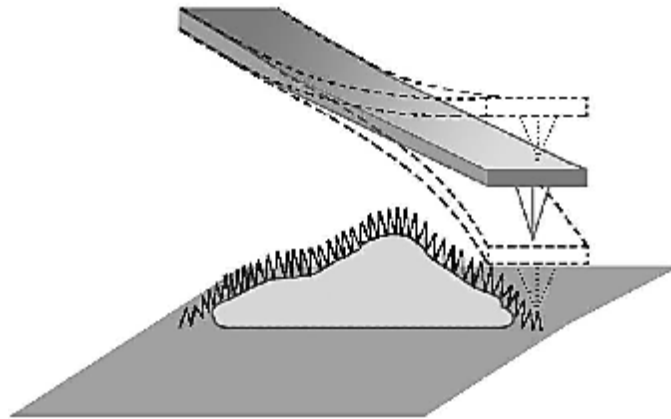

Fig. 6.7. Schematic diagram of tapping mode AFM operation

In **non-contact mode** the cantilever is located above the surface of the sample at distance such that it is no longer in the repulsive regime (5–100 nm) but in the attractive regime with interaction force of the order of  $10^{-8}$ – $10^{-14}$  N.

#### 6.4. COMPARISON OF AFM, SEM/TEM AND OPTICAL MICROSCOPE

Optical and electron microscopes can produce two dimensional magnified images of a sample surface, with a magnification as great as 1000X for an optical microscope, and as large as 100.000X for an electron microscope.

One of the great advantages of the AFM is the ability to magnify in the X, Y and Z axes and give three dimensional magnified images with the information about the height and depth of the sample surface features. AFM can scan surfaces with up to nanometer (molecular) lateral resolution, and up to 0.01 nm vertical resolution.

SEM is conducted in a vacuum environment therefore special events should be followed in sample preparation. AFM has the advantage of being able to image live cells under ambient and physiological conditions, in particular, in buffer solutions, *in situ*, and *in vitro*, if not *in vivo*.

With the AFM, little or no sample preparation is required while in SEM many pre-treatments to be followed due to vacuum environment and electron beam. Moreover unlike electron microscopes AFM is nondestructive to the sample surface (table 1).

Table 1

**Comparison of an AFM, SEM/TEM and optical microscope**

Method	Lateral resolution	Environment	Magnification	Effect on the sample
Optical microscope	200 nm	Air Liquid	2-Dimentional	nondestructive to the sample
SEM/TEM	0,1 nm (TEM) 1-20 nm (SEM)	Vacuum	2-Dimentional	destructive to the sample
AFM	1-20 nm	Vacuum Air Liquid	3-Dimentional	nondestructive to the sample

The lateral resolution of optical microscope depends on the wavelength of the light, on the numerical aperture of the optical arrangement. The resolution of the light microscope is limited by wavelength of light (diffraction). The lateral resolution of SEM is limited by the size/ brightness of the electron beam and the sensitivity of the detector, whereas AFM resolution is determined by the physical size and radius of curvature of the AFM tip and sample roughness.

In comparison with an optical microscope and the SEM/TEM an AFM is more difficult to use than the optical microscope and easier to use than the SEM/TEM. Also, the AFM is typically more expensive than the optical microscope and less costly than an SEM/TEM.

Although light microscope and electron one can be used only for imaging, AFM can be used to measure various biophysical properties of biomedical objects, such as elasticity, adhesion, hardness, friction in addition to imaging. Moreover AFM can provide a minutely controllable nanoprobe (tip) to maneuver cell structures. AFM can apply precise mechanical stimuli and measure very low force interactions between or even within single molecules.

Atomic force microscopy potential to image the structure of biomedical objects surface with molecular or even sub-molecular resolution, study samples under physiological conditions (which allows to follow in situ the real time dynamics of some biological events), measure local chemical, physical and mechanical properties of a sample and manipulate single molecules make it a tool of undeniable value for biomedical microscopy investigations.

## QUESTIONS

1. What are the differences between convex and concave lenses? Describe their properties. Give the definition of an optical power.
2. Explain principles of the image formation by thin lenses. What is a real image? What is a virtual image?
3. Write a formula of thin lens. How is a thin lens magnification determined?
4. What is a simple magnifier? What type of image does it form?
5. Plot a ray tracing in the optical microscope.
6. Write a formula for optical microscope magnification.
7. By what is a microscope resolution limit determined? Write Abbes' formula. Give a numerical value for optical microscope resolution limit.
8. What is the wave particle duality concept? Give the formula for the de Broglie's wavelength.
9. Describe the main principles of electron microscope operation.
10. How is an electron microscope resolution limit determined?
11. What are the differences between electron and atomic force microscopes?

## PROBLEMS

1. In the microscope with a magnification 500 times (500X), the focal length of the eyepiece is 4 cm and the length of the optical tube is 20 cm. Find the focal length of the objective.
2. In the optical microscope using light with a wavelength of 450 nm, the minimum resolution limit is equal to 0.3 microns. Find the minimum limit of microscope resolution, if the used wavelength is 600 nm.
3. In the optical microscope with dry objective the minimum resolvable distance is 0.45 microns. Find the resolution limit of the microscope if oil with refractive index of 1.5 is used between the objective lens and the specimen.
4. Microscope has an objective with the focal length of 2.5 mm and the diameter of 6 mm. Find the microscope resolution limit when the wavelength of light being used is equal to 490 nm (green-blue light).
5. How many times the object size being studied by a microscope with a numerical aperture of 0.20 ( $NA = 0.20$ ) may be less than the object size observed by the normal eye at a distance of best vision? The calculation has to be carried out for the wavelength  $\lambda = 0,555$  microns.

## REFERENCES

1. *Murphy, D. B.* Fundamentals of light microscopy and electronic imaging / D. B. Murphy. J. Wiley & Sons, 2001. 357 p.
2. *Allen, T.* Introduction to electron microscopy for biologists, methods in cell biology / T. Allen. Academic Press, 2008. 560 p.
3. *Chen, C. J.* Introduction to scanning tunneling microscopy / C. J. Chen. Oxford University Press, 1993. P. 313–324.
4. *Wiesendanger, R.* Scanning probe microscopy and spectroscopy, methods and applications / R. Wiesendanger. Cambridge University Press, 1994. 206 p.
5. *Mironov, V. L.* Fundamentals of scanning probe microscopy / V. L. Mironov. Moscow, 2004. 144 p.

## CONTENTS

INTRODUCTION.....	3
PART 1. LENS OPTICS .....	4
1.1. Lens Optics Characteristics.....	4
1.2. Image Formation by Thin Lenses.....	6
1.3. Thin Lens Formula .....	7
1.4. Thin Lens Magnification.....	7
PART 2. OPTICAL ABERRATIONS.....	8
2.1. Spherical Aberration .....	8
2.2. Chromatic Aberration .....	9
PART 3. SIMPLE MAGNIFIER.....	10
PART 4. OPTICAL MICROSCOPY.....	11
4.1. Fundamentals of an Optical Microscope .....	11
4.2. Resolution and Resolution Limit.....	13
PART 5. ELECTRON MICROSCOPY .....	16
5.1. Fundamentals of an Electron Microscope .....	16
PART 6. ATOMIC FORCE MICROSCOPY .....	21
6.1. Fundamentals of an Atomic Force Microscope.....	21
6.2. Force Interaction between Tip and Sample .....	24
6.3. Modes of AFM Operation.....	25
6.4. Comparison of AFM, SEM/TEM and Optical Microscope .....	26
QUESTIONS .....	28
PROBLEMS.....	28
REFERENCES.....	29

Учебное издание

**Кухаренко Людмила Валентиновна**  
**Недзьведь Ольга Валерьевна**

**ОПТИЧЕСКАЯ, ЭЛЕКТРОННАЯ  
И АТОМНО-СИЛОВАЯ МИКРОСКОПИИ**

**OPTICAL, ELECTRON AND ATOMIC FORCE  
MICROSCOPIES**

Учебно-методическое пособие  
На английском языке

Ответственный за выпуск В. Г. Лещенко  
Переводчики: Л. В. Кухаренко, О. В. Недзьведь  
Компьютерная верстка Н. М. Федорцовой

Подписано в печать 20.02.14. Формат 60×84/16. Бумага писчая «Снегурочка».  
Ризография. Гарнитура «Times».  
Усл. печ. л. 1,86. Уч.-изд. л. 1,6. Тираж 60 экз. Заказ 141.

Издатель и полиграфическое исполнение: учреждение образования  
«Белорусский государственный медицинский университет».  
Свидетельство о государственной регистрации издателя, изготовителя,  
распространителя печатных изданий № 1/187 от 18.02.2014.  
Ул. Ленинградская, 6, 220006, Минск.