

N. A. NIKONENKO, N. I. INSAROVA

**PHYSICAL PROPERTIES
OF DENTAL MATERIALS,
TISSUES OF TOOTH AND SKIN.
PRINCIPLES OF RHEOLOGY.
PHYSICAL BASIS OF ADHESION**

Minsk BSMU 2015

МИНИСТЕРСТВО ЗДРАВООХРАНЕНИЯ РЕСПУБЛИКИ БЕЛАРУСЬ
БЕЛОРУССКИЙ ГОСУДАРСТВЕННЫЙ МЕДИЦИНСКИЙ УНИВЕРСИТЕТ
КАФЕДРА МЕДИЦИНСКОЙ И БИОЛОГИЧЕСКОЙ ФИЗИКИ

Н. А. Никоненко, Н. И. Инсарова

**ФИЗИЧЕСКИЕ СВОЙСТВА
СТОМАТОЛОГИЧЕСКИХ МАТЕРИАЛОВ,
ТКАНЕЙ ЗУБА И КОЖИ. ЭЛЕМЕНТЫ РЕОЛОГИИ.
ФИЗИЧЕСКИЕ ОСНОВЫ АДГЕЗИИ**

**PHYSICAL PROPERTIES OF DENTAL MATERIALS,
TISSUES OF TOOTH AND SKIN. PRINCIPLES
OF RHEOLOGY. PHYSICAL BASIS OF ADHESION**

Учебно-методическое пособие

2-е издание, исправленное



Минск БГМУ 2015

УДК 577.3:616.314-77(811.111)-054.6 (075.8)
ББК 28.707 (81.2 Англ-923)
Н63

Рекомендовано Научно-методическим советом университета в качестве
учебно-методического пособия 17.06.2015 г., протокол № 10

Р е ц е н з е н т ы: д-р техн. наук, проф. Белорусского национального техническо-
го университета И. З. Джилавдари; канд. физ.-мат. наук, доц. Белорусского госу-
дарственного медицинского университета В. Г. Лещенко

Никоненко, Н. А.

Н63 Физические свойства стоматологических материалов, тканей зуба и кожи.
Элементы реологии. Физические основы адгезии = Physical properties of dental
materials, tissues of tooth and skin. Principles of rheology. Physical basis of adhesion :
учеб.-метод. пособие / Н. А. Никоненко, Н. И. Инсарова. – 2-е изд., испр. –
Минск : БГМУ, 2015. – 52 с.

ISBN 978-985-567-294-5.

Издание содержит необходимые врачу-стоматологу сведения о физических свойствах тканей
зуба и кожи, а также используемых в стоматологии материалов. Рассматриваются элементы
реологии и физические основы адгезии. Обсуждается не только сущность того или иного
физического явления, но и его значение в стоматологической практике. Первое издание вышло
в 2012 году.

Предназначено для иностранных студентов с обучением на английском языке.

УДК 577.3:616.314-77(811.111)-054.6 (075.8)
ББК 28.707 (81.2 Англ-923)

ISBN 978-985-567-294-5

© Никоненко Н. А., Инсарова Н. И., 2015
© УО «Белорусский государственный
медицинский университет, 2015

INTRODUCTION

The main aim of this textbook is to present the basic physical properties of the dental materials as they are related to its utilization by the dentist. One of the differences between a professional dentist and a tradesman of the dental materials is that the former possesses basic knowledge which allows him to solve the particular clinical problem with an ensured success.

The dentist and the engineer have much in common. If the engineer knows nothing about the physical (first of all mechanical and thermal) properties of the steels and other materials planned for the bridge, the construction would undoubtedly fail.

A dentist as an engineer should analyze the possible behavior of a future dental construction and to be able to optimize it. He should possess sufficient knowledge of the physical properties of the different types of materials he is using so that he can make the best selection of materials for this particular restoration. In other words, he must know whether the dental operation requires the use of a gold alloy, a metal-ceramic, a cement, or a synthetic resin, for example. Only if he knows the physical properties of each of these materials he is able to make such a judgment.

It is obvious that the student, the future dentist, should not ignore the science of dental materials.

Above we meant the physical properties of different dental materials in solid state. However, many, if not most, of these materials are liquid at some stage in their dental application. Moreover, the success or failure of the use of given material may depend on its properties in the liquid state. Therefore this textbook contains a part «Principles of rheology».

The phenomenon of adhesion (of bonding) is involved in many situations in dentistry. That is why the part «Physical basis of adhesion» is included in this textbook as well.

PART 1

PHYSICAL PROPERTIES OF DENTAL MATERIALS AND TISSUES OF TOOTH

1.1. MECHANICAL PROPERTIES OF DENTAL MATERIALS

Mechanical properties of materials are revealed in their response to the action of the external forces. The external force will be called the load on the body. In oral cavity the load may be as much as approximately 900 N.

Two types of load (static and dynamic) are defined. *Static load* increases gradually from the zero to the certain value which does not vary with time. The examples of *dynamic load* are impact and repetitively variable (cyclic). *Repetitively variable* load repeatedly acts on an object and varies both on magnitude and the direction. Repetitively variable load arises, for example, upon mastication.

Strain and stress. Changes of shape and (or) dimensions of the sample which is made from some material under action of the external forces is called *strain (deformation)*.

Strain may be either elastic or plastic. *Elastic strain is reversible*; it disappears after the load is removed. *The deformation is called plastic (permanent)* when the object does not return to its original dimensions and shape after load removing. In this case the body will be permanently deformed.

Different types of strains are defined in accordance to the direction of the load acting on the body, as shown in fig. 1.1. The deformed sample is shown by dashed line.

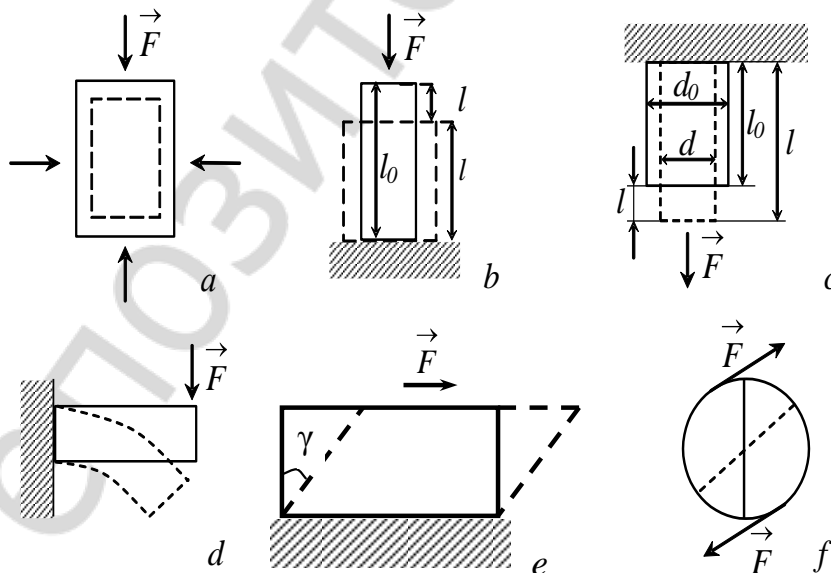

Fig. 1.1. The different types of deformation:
a — uniform compression; *b* — axial compression; *c* — axial tension; *d* — bending; *e* — shear; *f* — torsion. The directions of external forces (loads) are indicated by arrows

It can be shown that the different types of strain of a body can be reduced to the two main types: to shear and tensile (compressive) strain.

In oral cavity the acting of external forces tends to compression, tension, shear, and bending of corresponding structural elements.

Let us define the main physical values which characterize the behavior of the deformed body.

Quantitative measure of deformation is an absolute and relative deformation.

For example, let us consider the case of *an axial tension* (fig. 1.1, c). A load tends to stretch (elongate) a body (fig. 1.1, c). Then absolute deformation (the increase in length) is equal to $\Delta l = l - l_0$, where l_0 is the original length; l is the elongated length.

Relative deformation (strain) ε is defined as:

$$\varepsilon = \frac{\Delta l}{l_0}. \quad (1.1)$$

The value of ε is dimensionless, it is usually expressed in percents (%).

When an external force F acts upon a solid body (the body is deformed), a reaction force (internal force) arises within the body that is equal in magnitude but opposite in direction to the external force. The internal force is characterized by *the mechanical stress* σ . For an axial tension the value of *stress* σ (tensile stress) is defined as the average force F per unit cross-sectional area S within the body on which external force acts:

$$\sigma = \frac{F}{S}. \quad (1.2)$$

In the SI system stress is measured in the pascals (symbol Pa), which is defined as one newton per square meter: $1 \frac{N}{m^2} = Pa$. In the English system of measurement, the stress is usually measured in pounds per square inch.

As an illustration, assume that a stretching force, or load, of 200 newtons is applied to a wire with the cross-sectional area equal to $0.2 \cdot 10^{-5}$ square meters. The stress, by definition, will be the force over unit area, or

$$\sigma = \frac{200}{0.2 \cdot 10^{-5}} = 10^8 Pa = 100 MPa.$$

If the wire of 0.1 meter long, stretched to 0.001 meter under the load, the strain, by definition, would be the change in length per unit length, or

$$\varepsilon = \frac{0.001}{0.1} = 0.01 \text{ (1.0 \%)}.$$

Let us consider some more examples.

Axial compression. If a body is placed under a load that tends to compress or shorten it, the internal resistance to such a load is called a compressive stress

(fig. 1.1, *b*). And corresponding deformation is called a compressive strain. With both tensile and compressive stresses, the forces are applied at right angles to the area over which they act.

Shear. The measure of shear strain is the angle γ (the angle of shear) which is indicated in fig. 1.1, *e*. A stress that tends to resist a twisting motion, or a sliding of one portion of a body over another, is a shear stress τ which is defined as $\tau = F/S$, where the force F acts on tangent to the surface of a body, S is the area of this surface.

Note that the shear stress results from forces that act parallel to the surface of the object.

Complex stresses. It is extremely difficult to induce a stress of a single type in a body. For example, when a wire is stretched, the experimentally observed stress is tensile, but cross-sectional area is decreased, that obviously indicates the presence of compressive stresses (fig. 1.1, *c*).

In other words, when a tensile force is applied to the body, the increase in length (tensile strain $\epsilon = \frac{\Delta l}{l_0}$) is accompanied by a decrease in the transverse dimension of the object ($\epsilon' = \frac{\Delta d}{d_0}$), i. e. the object becomes longer and thinner

(fig. 1.1, *c*). Accordingly, upon tension $\epsilon > 0$ (positive), but $\epsilon' < 0$ (negative).

Conversely, a compressive force acts to make an object shorter but thicker (fig. 1.1, *b*). Upon compression $\epsilon < 0$ (negative), $\epsilon' > 0$ (positive).

The ratio of $\frac{\epsilon'}{\epsilon}$ is the property of the material and is called Poisson's ratio (Poisson coefficient) μ :

$$\mu = -\frac{\epsilon'}{\epsilon} > 0. \quad (1.3)$$

For an ideal, isotropic material of constant volume, the ratio μ is equal to 0.5. Most dental materials have the value of Poisson coefficient of approximately 0.3.

Poisson coefficient depends on the properties of the material, from which the sample is made. Its value also determines the relative change of the body volume $\frac{\Delta V}{V_0}$ upon elastic deformation:

$$\frac{\Delta V}{V_0} = \epsilon(1 - 2\mu), \quad (1.4)$$

where V_0 is the original volume, and $\Delta V = V - V_0$ is the absolute change of the volume of the body upon deformation; V is the final volume.

If $\mu = 0.5$ the material is called incompressible. Liquids are an example of incompressible mediums.

In the daily practice of dentistry the Poisson coefficient should be accounted for in the proper choosing the materials for dental restorations. To extend the service life of dental restorations the following condition should be met:

$$\mu_{\text{tooth}} \approx \mu_{\text{restoration}}$$

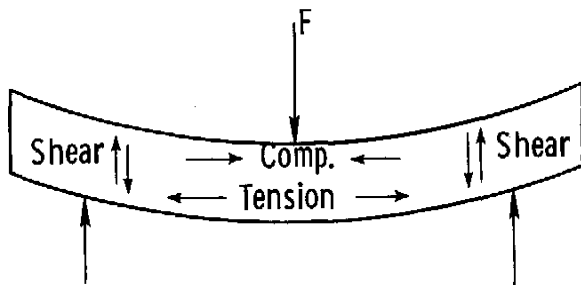

Fig. 1.2. Complex stress as produced by three-point loading of a beam

Another example of complex stress, as shown in fig. 1.2, is produced by bending a beam in three-point loading. This situation is commonly encountered in the construction of a fixed bridge in prosthetic dentistry. As can be seen, compressive, tensile, and shear stresses are present in various parts of the structure.

The stress-strain behavior of the object made from some material is characterized by certain magnitudes. Let us consider some of them.

If the stress-strain behavior is plotted on a graph, a curve that represents a continuous response of the material to the imposed force is called the stress-strain curve.

Elastic limit. If a small tensile stress is induced in a wire, the resulting strain may be such that the wire will return to its original length when the load is removed.

If the load is increased progressively in small increments, and then released after each addition of stress, a stress value finally will be found at which the wire does not return to its original length after it is unloaded. In such a case, the wire is said to have been stressed beyond its elastic limit. *The elastic limit of a material is the greatest stress to which a material can be subjected, such that it will return to its original dimensions when the forces are released.* Although tensile stress was used in the illustration, the same situation can exist with any type of stress.

Proportional limit. If the wire discussed above is loaded in tension in small increments until the wire ruptures, without removal of the load each time, and if each stress is plotted on a vertical coordinate and the corresponding strain is plotted on the horizontal coordinate, a curve similar to that in fig. 1.3 is obtained. It can be noted that the curve starts as a straight line but gradually curves after a certain stress value is exceeded. If a ruler is laid on the straight-line portion of the curve (from *O* to *P*), and if the straight line is extended in a dotted line (b) as shown, the stress at the point *P*, at which the curve digresses from a straight line, is known as *the proportional limit*.

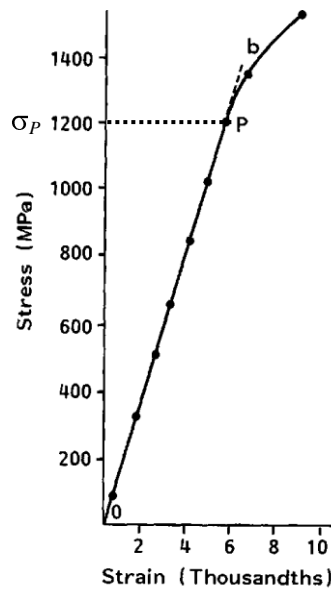

Fig. 1.3. Stress-strain curve for a stainless steel orthodontic wire under tension (static loading). Proportional limit, 1200 MPa; modulus of elasticity, 200 MPa; modulus of resilience, 3.6 megajoules per cubic meter; ultimate tensile strength, 1520 MPa

It is a *fundamental law (Hooke's law)* that the stress is directly proportional to the strain upon elastic deformation:

$$\sigma = E \cdot \epsilon, \tag{1.5}$$

where E is called *Young's modulus or the modulus of elasticity*.

Since direct proportionality between two quantities is graphically a straight line, the straight-line portion of the graph in fig. 1.3, which was plotted from actual data, is the confirmation of this law. *The proportional limit (stress corresponding to the point P or σ_P) is the greatest stress that may be produced in a material such that the stress is directly proportional to the strain.* A stress- strain curve for dentin under compression is shown in fig. 1.4.

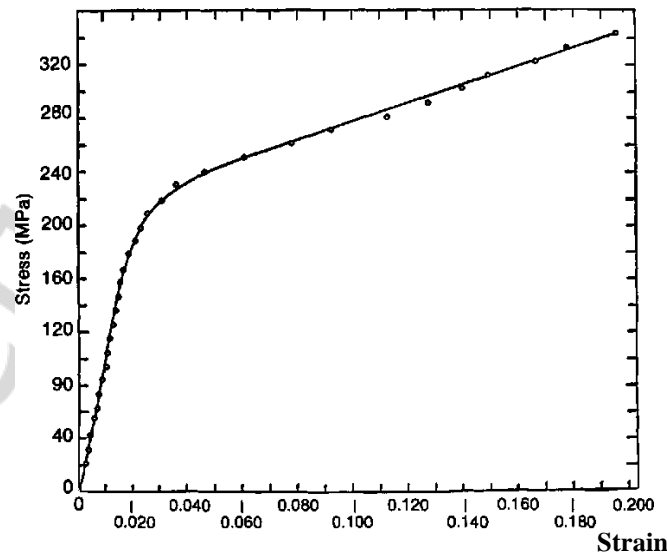

Fig. 1.4. A stress-strain curve for dentin under compression (static loading) (As an exercise, the student may determine the proportional limit and modulus of elasticity from the curve)

Modulus of elasticity. From formula (1.5) it follows that modulus of elasticity is the value of the stress-strain ratio ($E = \frac{\sigma}{\epsilon}$). The unit for the modulus is the same as that of stress because strain is dimensionless:

$$E = \frac{N}{m^2} = Pa.$$

Since the modulus of elasticity is the ratio of the stress to the strain, it follows that the less the strain for a given stress, the greater will be the value of the modulus. The stiffer a material is, the higher the value E .

In fig. 1.3 and 1.4, if any stress value equal to or less than the proportional limit is divided by its corresponding strain value, the modulus of elasticity or Young's modulus will result.

If, instead of uniaxial stress, a shear stress (τ) predominated, then the following relationship is valid:

$$\tau = G \cdot \gamma, \quad (1.6)$$

where G is the shear modulus; γ is the angle of shear (the shear strain).

The shear modulus for the material can be calculated from Young's modulus and Poisson's ratio. It is determined by

$$G = \frac{E}{2(1 + \mu)}. \quad (1.7)$$

Since a value of 0.3 for Poisson's ratio is typical, the shear modulus is usually about 40 percent of Young's modulus.

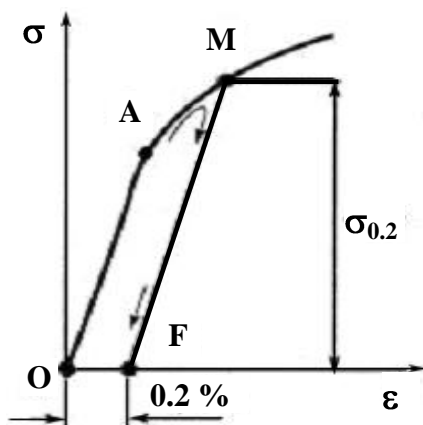

Fig. 1.5. Determination of yield strength from stress-strain curve using 0.2 percent offset

Yield strength. This magnitude represents the stress at which permanent deformation of the structure begins. The yield strength is important in the evaluation of dental materials. If the masticatory stress exceeds the yield strength value, the restoration or appliance may no longer fit as originally designed.

From a practical point of view, the question arises as to how much total permanent deformation can be tolerated in design application. This is an arbitrary choice that may vary from material to material or with a specific application. A value of 0.2 percent plastic strain is often used (called 0.2 percent offset) (fig. 1.5).

The stress at the point M corresponds to the yield strength.

Resilience. External forces acting upon a body made from some material do some work on its deformation. When a dental restoration is deformed, the acting force is the masticating force as it acts upon the structure. The magnitude of the deformation of the structure is determined by the induced stress.

When work is done upon a body potential energy is imparted to it and the elastically deformed object can also do some work on recovering its dimensions and shape. This ability of the material is characterized by the magnitude which is called the modulus of resilience or resilience (R). It is determined mathematically by dividing the square of the proportional limit σ_P by the double the modulus of elasticity E :

$$R = \frac{1}{2} \cdot \frac{\sigma_P^2}{E}. \quad (1.8)$$

As far as $E = \frac{\sigma_P}{\epsilon_m}$, where ϵ_m is the strain corresponding to the stress σ_P ,

then $R = \frac{1}{2} \cdot \sigma_P \cdot \epsilon_m$.

The units for the modulus of resilience are expressed as energy per unit volume: $[R] = \text{J/m}^3$ (joules per cubic meter).

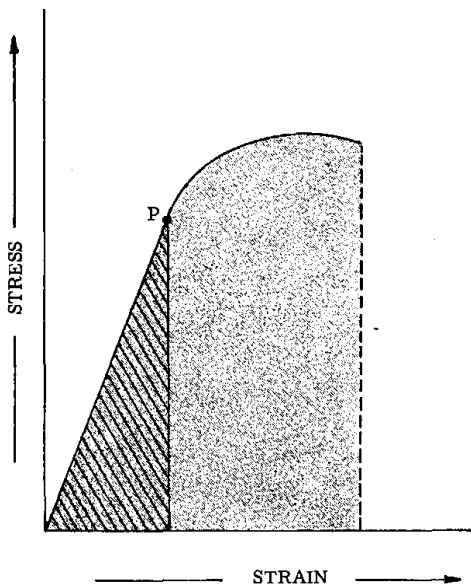

Fig. 1.6. Stress-strain curve as determined by application of a tensile stress. The proportional limit is shown at P

It is worth noting that the modulus of resilience is equal to the area under the straight-line portion of the stress-strain curve, as illustrated in fig. 1.6 (cross-hatched area).

Formula (1.8) is very important as a criterion for the selection of a dental material. The point is that in most dental restorations, large strains are precluded because of the dangers of damage to the tooth. Hence, a high modulus of elasticity (E) and a high modulus of resilience are imperative for a successful tooth restorative material. According to the formula (1.8), to attain a high modulus of resilience, a high proportional limit (σ_P) is necessary.

Permanent (plastic) deformation. As can be noted in fig. 1.7, the stress-strain curve is no longer a straight line above P but rather curves until the structure fractures. The stress-strain curve shown in fig. 1.7 is more complete and typical. Unlike the curve at stresses below the proportional limit σ_P , the exact path of the curve above P may be unpredictable. It should also be noted that the stress is no longer proportional to the strain.

If the load is removed at any point prior to the fracture, the stress resulting from the load becomes zero, but, as noted by the broken line extending to the horizontal coordinate (fig. 1.7), the strain does not become zero; hence

the wire or whatever structure does not return to its original dimension. It is permanently deformed.

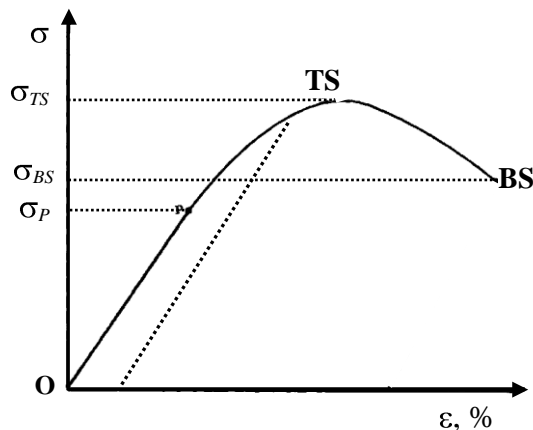

Fig. 1.7. Complete stress-strain curve as determined under tension (static loading); σ_P , proportional limit; σ_{TS} , tensile strength; σ_{BS} , breaking strength

Strength. The strength (ultimate strength) is defined as the maximal stress which the structure will withstand before rupture. Depending upon the type of stress there are different strengths, for example, tensile strength, compressive strength or shear strength.

It is worth noting that, the tensile strength σ_{TS} is not equal to the breaking strength σ_{BS} , as shown in fig. 1.7.

Many brittle materials have a tensile strength that is markedly lower than the strength of the plastic materials. This is true for various dental materials, for example, amalgam and porcelain.

Fatigue. Strength values obtained from any of these static «one time» measurements may be quite misleading if they are used to design a structure that will be subject to repeated or cyclic loading. It has been empirically demonstrated that cyclic loading at stress values well below the ultimate strength can produce abrupt failure of a structure. This phenomenon is called *fatigue*. It is very important for dentistry because normal mastication can produce thousands of stress cycles on the dental material per day.

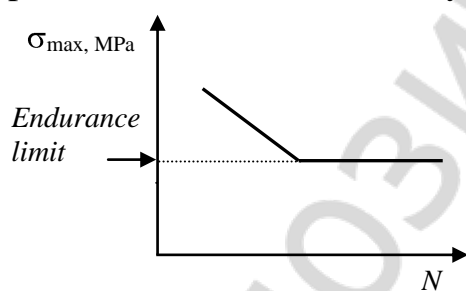

Fig. 1.8. Typical curve of a fatigue testing result: maximum stress (σ_{max}) versus number of cycles (N)

Fatigue behavior is studied by subjecting a material to a cyclic loading and thus determining the number of cycles that are required to produce failure. A plot of the maximum stress (σ_{max}) against the number of cycles before failure enables calculation an *endurance limit* — the maximum stress magnitude at which a material withstands an infinite number of cyclic loading (fig. 1.8).

Some ceramic materials exhibit a phenomenon referred to as *static fatigue*. These materials will support a high static load for a long period of time and then fail abruptly. This type of failure occurs only when the materials are stored in a wet environment and is related to the effects of water on the highly stressed surfaces of the material.

Impact strength. Impact strength (KCU или KCV) may be defined as the energy required to fracture a material under impact loading. It can be

measured by subjecting the specimen of known dimensions to a swinging pendulum (fig. 1.9).

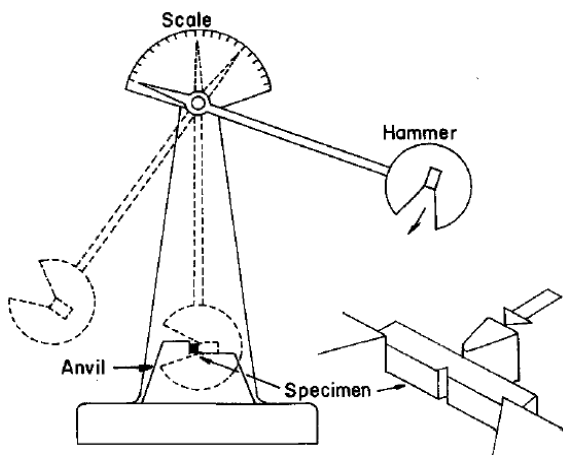

Fig. 1.9. Schematic drawing of a standard impact testing apparatus

The amplitude change of the swing of the pendulum is the measure of the energy absorbed by the specimen. From this the impact strength or energy can be calculated. Usually the impact testing requires a large number of samples because there is a large variation in results.

The unit for impact strength is the energy per unit cross-sectional area: $[KCU \text{ or } KCV] = J/m^2$ (joules per square meter).

The less the impact strength value, the more brittle is the material.

Toughness. It can be defined as the energy (work) required to fracture a material. *Toughness* can be measured as the total area under the stress-strain curve from zero stress to the breaking strength (fig. 1.10).

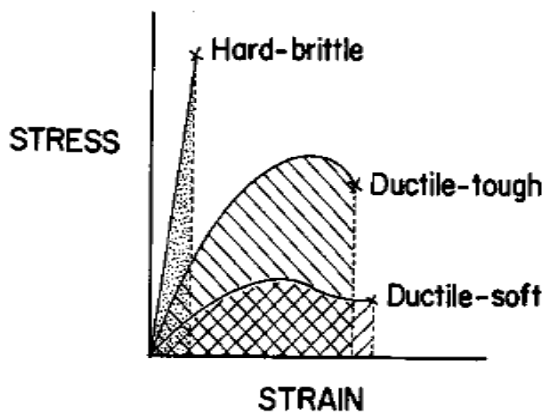

Fig. 1.10. Stress-strain curves of materials exhibiting different characteristics under stress. The areas underneath the curves are the measure of toughness

A material that can withstand high stresses and will undergo considerable plastic deformation (ductile-tough material) is tougher than the one which resists high stresses but has no capacity for deformation (hard brittle material) or one which has a high capacity for deformation but can only withstand relatively low stresses (ductile-soft or plastic material) (fig. 1.10).

Brittleness. Brittleness is generally considered to be the opposite of toughness. For example, glass is brittle at room temperature; it will not bend appreciably without breaking. In other words, a brittle material is apt to fracture at or near its proportional limit.

However, a brittle material is not necessarily lacking in strength. For example, the shear strength of glass is low, but its tensile strength is very high. If the glass is drawn into a fiber, its tensile strength may be as high as 2800 MPa. Tested in the same manner, the tensile strength of quartz may exceed 7000 MPa.

Relaxation. After a substance has been permanently deformed, there are trapped internal stresses. For example, in a crystalline substance the atoms in

the space lattice are displaced, and the system is not in equilibrium. Similarly, in amorphous structures, some molecules are too close together and others too far apart after the substance has been permanently deformed.

It is understandable that such a situation is not very stable. The displaced atoms may be said to be «uncomfortable» and wish to return to their normal, regular relative positions. Given time, by diffusion they will slowly move back to their equilibrium relationship. The result is a change in the shape or contour of the solid as a gross manifestation of the rearrangement in atomic or molecular positions. The material is said to *warp* or *distort*. Such a relief of stress is known as *relaxation*.

As can be expected, the rate of relaxation will increase with an increase in temperature. For example, if a wire is bent, it may tend to straighten out if it is heated to a high temperature. At room temperature, any such relaxation or diffusion may be negligible. On the other hand, there are many noncrystalline dental materials (e. g., waxes, resins, gels) that can relax during storage at room temperature after being bent or molded.

Hardness. Surface hardness is the result of the interaction of numerous properties. Among the properties that influence the hardness of a material are its strength, proportional limit, ductility, malleability, and resistance to abrasion and cutting. Because numerous factors influence hardness, the term is difficult to define. In fact, no specific definition exists. In mineralogy the relative hardness of a substance is based upon its ability to resist scratching. In metallurgy, and in most other disciplines, the concept most generally accepted is the «resistance to indentation». It is upon this precept that most modern hardness tests are designed.

Despite the lack of specificity of the term, knowledge of the hardness of materials is useful to the engineer and furnishes valuable information to the dentist.

There are many surface hardness tests. Most are based upon the ability of the surface of a material to resist penetration by a point under a specified load. The tests most frequently used in determining the hardness of dental materials are the Brinell, Vickers, and Knoop (table 1.1). The selection of the test is often determined by the material being measured.

The Brinell test is one of the oldest tests employed for determining the hardness of metals. In the Brinell test, a hardened steel ball is pressed into the polished surface of a material under a specified load, as diagrammed in table 1.1.

The load (P) is divided by the area of the surface of the indentation (S) and the quotient is referred to as the *Brinell Hardness number (BHN)* $BHN = \frac{P}{S}$.

Thus, the smaller the indentation, the larger is the hardness number, and the harder is the material.

Table 1.1

Hardness tests

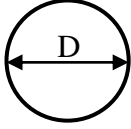
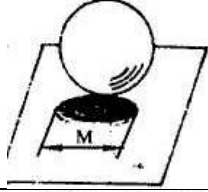
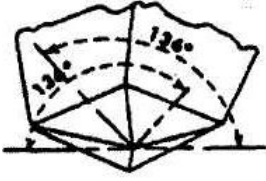
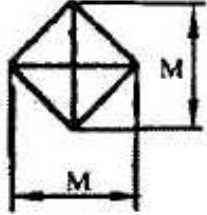
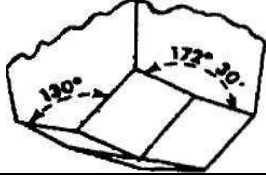
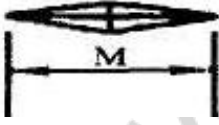
Test	Indenter	Shape of indenter	Shape of indentation	Formula for hardness number
Brinell	Steel or tungsten carbide sphere			$BHN = \frac{P}{D^2} \left[\frac{\frac{2}{\pi}}{1 - \sqrt{1 - \left(\frac{M}{D}\right)^2}} \right]$
Vickers	Diamond pyramid			$VHN = 1.854 \frac{P}{M^2}$
Knoop	Diamond pyramid			$KHN = 12.87 \frac{P}{M^2}$

The Brinell test has been used extensively for determining the hardness of metals and metallic materials used in dentistry. In addition, the *BHN* is related to the proportional limit and the ultimate tensile strength of dental gold alloys. As the test is a relatively simple one, it may often be conveniently used as an index of properties that involve a more complicated test method.

However, the application of this test to all dental materials is somewhat limited. It is not suitable for determining the hardness of brittle materials or those that exhibit significant elastic strain. Thus, the Brinell test is not suitable for measuring the hardness of tooth structure and cements, which are brittle materials, or the dental plastics, which exhibit elastic recovery.

The *Vickers hardness* test employs the same principle of hardness testing as the Brinell test. However, instead of a steel ball, a diamond in the shape of a square-based pyramid is used (table 1.1). Although the impression is square instead of round, the method for computation of the *Vickers hardness number* (*VHN*) is the same as that for the Brinell hardness number in that the load is divided by the area of indentation. The lengths of the diagonals of the indentation are measured and averaged. The Vickers test is employed for dental casting golds. The test is suitable for determining the hardness of quite brittle materials. Therefore, it has been used for measuring the hardness of tooth structure. However, the Vickers suffers shortcomings in its use with the materials that exhibit elastic recovery.

The *Knoop hardness* test employs a diamond indenting tool that is cut in the geometrical configuration shown in table 1.1. The impression is rhombic in

outline and the length of the largest diagonal is measured. The load is divided by the projected area to give the *Knoop hardness number (KHN)*. When

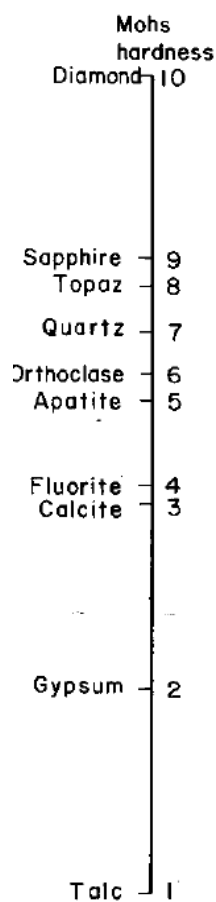

Fig. 1.11. Mohs' scale

the indentation is made, a cutting action occurs along the major axis of the impression, and a spreading takes place along the minor axis. The stresses are therefore distributed in such a manner that primarily only the dimensions of the minor axis are subject to change by relaxation. Thus, the hardness value is virtually independent of the ductility of the material tested. The hardness of tooth enamel can be compared with that of gold, porcelain, resin, and other tooth restorative materials. Also, the load may be varied over a wide range, from 1 gm to more than a kilogram, so that values for both exceedingly hard and soft materials can be obtained by this test.

The Knoop and Vickers tests are classified as microhardness tests in comparison with the Brinell macrohardness test. Both Knoop and Vickers employ loads less than 9.8 N. The resulting indentations are small and are limited to a depth of less than 19 μm . Hence they are capable of measuring very thin objects and giving hardness values of small regions. The Brinell test gives average hardness values over much larger areas.

Qualitatively the hardness may be estimated by *Mohs' scale* shown in fig. 1.11.

1.2. MECHANICAL PROPERTIES OF TOOTH TISSUES

There are two types of teeth, deciduous (or primary) and permanent; the latter is more important for understanding implantation. All teeth are made of two portions, the crown and the root, demarcated by the gingiva (gum). The root is placed in a socket, called the alveolus, in the maxillary (upper) or mandibular (lower) bone. A sagittal cross section of a permanent tooth is shown in fig. 1.12 to illustrate various structural features.

Tooth enamel is the hardest substance found in the body and consists almost entirely of calcium phosphate salts (97 percent) in the form of large apatite crystals. Dentin is another mineralized tissue whose distribution of organic matrix and mineral is similar to the regular bone and its physical properties. The collagen matrix of the dentin might have a somewhat different molecular structure than normal bone; it is more cross-linked, resulting in less swelling effect. Dentinal tubules (3–5 μm diameter) radiate from the pulp cavity toward the periphery and penetrate every part of dentin. Collagen fibrils

(2–4 μm diameter) are filled inside the dentinal tubules in longitudinal direction and the interface is cemented by protein-polysaccharides.

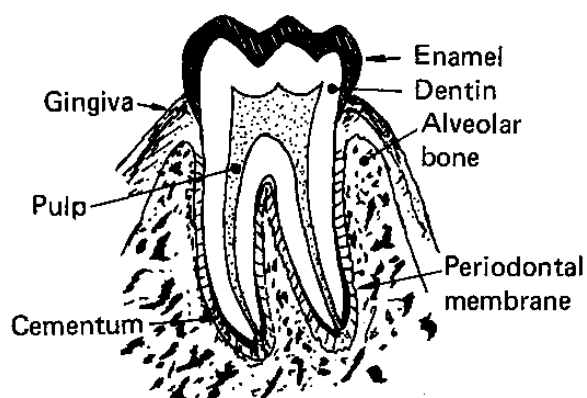

Fig. 1.12. Schematic diagram of a tooth

Cementum covers most of the root of the tooth with coarsely fibrillated bone substance but is devoid of canaliculi, Haversian systems, and blood vessels. The pulp occupies the cavity and contains thin collagenous fibers running in all directions and not aggregated into bundles. The ground substances, nerve cells, blood vessels, etc., are also contained in the pulp. The periodontal

membrane anchors the root firmly into the alveolar bone and it is made mostly of collagenous fibers plus glycoproteins, (protein-polysaccharides complex).

Many of the mechanical properties of human tooth structure have been measured, but the reported values vary markedly from one investigation to another. Undoubtedly, the differences are due to the technical problems associated with preparing and testing such minute specimens, in some instances less than 1 mm in length.

The results reported in one study are shown in table 1.2. Although the data in table 1.2 indicate a variation in the properties of enamel and dentin from one type of tooth to another, the difference probably is more the result of variation between individual teeth than between molar and cuspid, for example. However, the properties of enamel vary somewhat with its position on the tooth. Enamel on the cusp is stronger than that on the side of the tooth. Also, the properties vary according to the histological structure. For example, enamel is stronger under compression in a direction parallel to the enamel rods than in a direction perpendicular to the rods. On the other hand, the properties of the dentin appear to be quite independent of structure, regardless of the direction of compressive stress.

Table 1.2

Compressive Properties of Tooth Structure

Tooth	Structure	Modulus of elasticity, MPa	Proportional limit, MPa	Strength, MPa
Molar	Dentin	12000	148	305
	Enamel	46000	224	261
Bicuspid	Dentin	14000	146	248
Cuspid	Dentin	14000	140	276
	Enamel	48000	194	288
Incisor	Dentin	13000	125	232

Tensile properties of tooth structure have also been measured. Dentin is considerably stronger in tension than is enamel, the tensile strength is equal to 51.5 MPa and 10.3 MPa, respectively.

Although the compressive strengths of the enamel and dentin are comparable, the proportional limit and modulus of elasticity of enamel are higher than the similar properties of dentin. The higher modulus of elasticity results in a lower modulus of resilience of enamel in comparison with dentin.

1.3. THERMAL PROPERTIES OF DENTAL MATERIALS AND TISSUES OF TOOTH

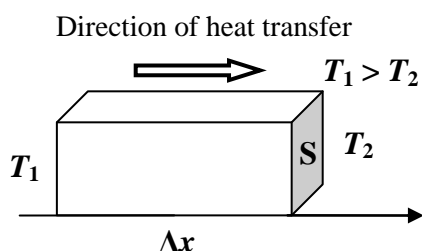

Fig. 1.13. Conduction

Heat transfer through solid substances most commonly occurs by means of a process called conduction (fig. 1.13).

The coefficient of *thermal conductivity* λ is measured by determining the quantity of heat (in joules per second) that passes through a specimen 1 m thick (Δx) having a cross-sectional area S of 1 m² when the temperature differential between the ends of the specimen ($T_1 - T_2$) is equal to 1 K. The higher the value of λ , the greater is the ability of the substance to transmit energy, and vice versa. The unit λ is expressed as follows: $[\lambda] = \text{W/m}\cdot\text{K}$, where 1 W (Watts) is equivalent to 1 J/s.

Generally, thermal conductivity of metals is much higher than ceramics and polymers because the free electrons in metals act as energy conductors.

However, more often the temperatures are not held constant. Generally there is an unsteady state, since the thermal transfer through the material decreases the thermal gradient. Under such conditions, thermal diffusivity is important. The mathematical formula for calculating *the thermal diffusivity* k is

$$k = \frac{\lambda}{c \cdot \rho}, \quad (1.9)$$

where λ is the thermal conductivity, c is the specific heat (J/kg·K), and ρ is the density (kg/m³). Thermal diffusivity k units are m²/s: $k = [\text{m}^2/\text{s}]$.

For a given volume of material, the heat required to raise the temperature of the given amount depends upon its the specific heat c and the density ρ . When the product of the specific heat and density is high, the thermal diffusivity may be low, even though the thermal conductivity is relatively high.

Therefore, both the thermal conductivity and thermal diffusivity are the important parameters in predicting the transfer of thermal energy through a material. Since an unsteady state of heat transfer exists during the ingestion of hot or cold foods and liquids, the thermal diffusivity of a dental restorative material may be more important than its thermal conductivity.

As can be noted in table 1.3, dentin and enamel are effective thermal insulators. Their thermal conductivity and diffusivity compare favorably with silica brick and water, in contrast with the markedly higher values for metals.

Table 1.3

Thermal properties of enamel and dentin as compared with other commonly recognized conductors and insulators

Material	Density, $\rho \cdot 10^{-3} \left(\frac{kg}{m^3} \right)$	Specific heat, $c \left(\frac{kJ}{kg \cdot K} \right)$	Conductivity, $\lambda \left(\frac{W}{m \cdot K} \right)$	Diffusivity, $k \cdot 10^6 \left(\frac{m^2}{s} \right)$
Enamel	2.91	0.75	0.92	0.42
Dentin	2.12	1.17	0.63	0.26
Silver	10.5	0.23	410.2	170
Copper	8.96	0.38	393.5	114
Silica brick	2.51	0.84	1.26	0.6
Water (20 °C)	1	4.2	0.59	0.14

However, as for any thermal insulator, tooth structure must be present in sufficient thickness to be effective. When the layer of dentin between the bottom of the cavity floor and the pulp is too thin, then the dentist should place an additional layer of an insulating base. The effectiveness of a material in preventing heat transfer is directly proportional to the thickness of the liner and inversely proportional to the square root of the thermal diffusivity \sqrt{k} .

Thus, the thickness of the remaining dentin and the base is as important as, if not more than, the thermal properties of the materials themselves.

The low thermal conductivity of enamel and dentin aids in preventing thermal shock and the resulting pain when hot or cold foods are taken into the mouth. However, the presence of oral restorations of any type tends to change the situation. Many restorative materials are metallic. Because of the free electrons present, these materials are such good thermal conductors that the tooth pulp may be adversely affected by the increased range of thermal changes. In many cases it is necessary to insert a heat insulator between the restoration and the tooth structure. In this respect, a restorative material that exhibits a low thermal conductivity is more desirable.

On the other hand, artificial teeth are held in a denture base, which ordinarily is constructed of a synthetic resin, a poor thermal conductor. In the upper denture, this base usually covers most of the roof of the mouth. Its low thermal conductivity tends to prevent heat exchange between the supporting soft tissues and the oral cavity itself. The patient partially loses the sense of heat and cold while eating and drinking. The use of a metal denture base might be more comfortable and pleasant from this point of view.

A thermal property equally important to the dentist is *the linear coefficient of thermal expansion*, which is defined as the change in length $\Delta L = L_2 - L_1$ per

unit length L of a material when its temperature is raised (or lowered) by one degree ($\Delta T = T_2 - T_1 = 1 \text{ K}$).

$$\alpha = \frac{\Delta L}{L_1 \cdot \Delta T} = \frac{L_2 - L_1}{L_1 (T_2 - T_1)} \quad (1.10)$$

where T_1 and T_2 are the initial and final temperatures of the body; L_1 and L_2 are the body length values at these temperatures.

In SI system the dimension of α is K^{-1} .

Linear coefficients of expansion of some substances of interest in dentistry are presented in table 1.4. As an example of the importance of this property in dentistry, a tooth restoration may expand or contract more than the tooth during a change in temperature; thus, the restoration may leak or become loosened. As a specific example, according to the values in table 1.4, a restoration made with a composite restorative material may change in dimension two times more than the tooth structure for every degree change in temperature.

Table 1.4

Linear coefficients of thermal expansion (α) of tissues of tooth and dental materials

Material	$\alpha \cdot 10^6 \text{ (K}^{-1}\text{)}$	α (related to tooth)
Tooth (crown)	11.4	1.0
Dental amalgam	25.0	2.2
Denture resin	81.0	7.1
Pit and fissure resin	85.0	7.5
Composite restorative material	20.0–25.0	1.8–2.0
Pure gold	14.0	1.2
Gold alloy	15.0	1.3
Aluminous porcelain	6.6	0.7
Silicone impression material	210.0	19.0

Upon heating the volume of solid body increases together with its linear dimensions. The volumetric thermal expansion coefficient is defined as

$$\beta = \frac{\Delta V}{V_1} \cdot \frac{1}{\Delta T} = \frac{V_2 - V_1}{V_1} \frac{1}{T_2 - T_1}, \quad (1.11)$$

where T_1 and T_2 are the initial and final temperatures of the body; V_1 and V_2 are the body volume values at these temperatures; $\Delta V = V_2 - V_1$ is the change in volume, $\Delta T = T_2 - T_1$.

In SI system the dimension of β is K^{-1} .

If the material is homogeneous then the volumetric thermal expansion coefficient β can be approximated:

$$\beta \approx 3\alpha.$$

PART 2 PHYSICAL PROPERTIES OF SKIN

The skin is considered to be a multilayered and homogeneous tissue. It is composed of three main layers, namely, epidermis, dermis and hypodermis. The epidermis is covered by the stratum corneum. The dermis is mostly responsible for the mechanical strength while the epidermis is primarily important for water conservation. The skin performs many other obvious functions such as a barrier for heat transfer, electrical shock, bacteria, or radiation. It may be stretched and elongated when subjected to large stress values. The skin exhibits anisotropy of properties: its physical (including mechanical) properties depend on the direction of testing.

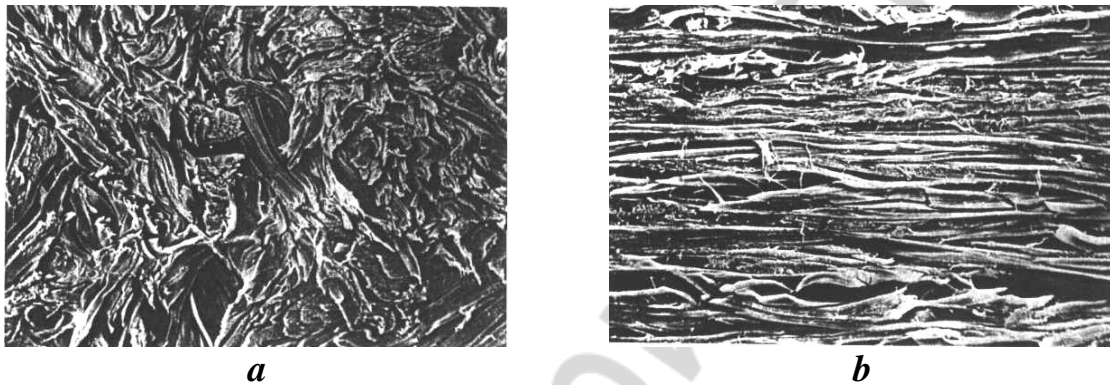

Fig. 2.1. The structure of dermal skin before (a) and after (b) stretching. 400x

The skin is composed largely of collagen and elastin with ground substances (mainly, mucopolysaccharides and interstitial (tissue) fluid). Collagen constitutes 75 % of the dry skin weight, elastin — about 4 %.

The skin has a feltwork of continuous fibers which are randomly arranged in layers or lamellae. The relations between the fibers define the behavior of skin upon stretching.

The structure of dermal skin before and after stretching in horizontal direction is shown in fig. 2.1. The pictures were obtained by electron scanning microscope. The feature of the stress-strain curve of the skin is its extensibility with a small load despite its high collagen content, which is largely a result of the highly random state of the dermal fibers. On stretching, the fibers align each with other and resist further extension, as can be seen in fig. 2.1.

Ground substances of skin exhibit negligible resistance to the action of the external forces. At small stress values the skin deformation is mainly determined by elastin ($E_{\text{elastin}} \approx 0.1\text{--}1.0$ MPa), while at large stress values collagen has a dominant role ($E_{\text{collagen}} \approx 100$ MPa). Therefore with increasing of the skin deformation its elastic resistance has small values initially (that is due to the elastin deformation) and then upon alignment of the collagen fibers it rises sharply as can be seen in fig. 2.2.

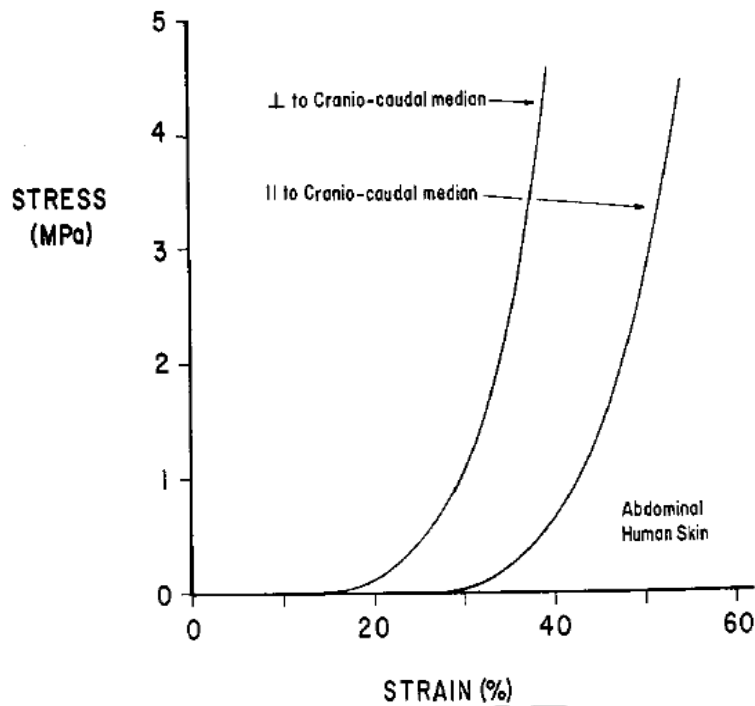

Fig. 2.2. Stress-strain curves of human abdominal skin

The skin is structurally anisotropic. Hence depending on the direction of testing, the response of load can be different, as shown in fig. 2.2.

The anisotropy is the reason behind the Langer's line, which follows the least resistant path of the dermis for easier surgery and better wound healing.

PART 3. PRINCIPLES OF RHEOLOGY

Up to this point, the discussion of the physical properties of materials used in dentistry has been devoted to the behavior of solid materials subjected to various types of stress. However, many, if not most, of these materials are liquid at some stage in their dental application. Moreover, the success or failure of a given material may be dependent both on its properties in the liquid state and its ultimate properties as a solid.

For example, materials like cements and impression materials undergo a liquid to solid transformation in the mouth. Gypsum products used in the fabrication of models and dies and casting alloys are materials that are shaped as liquids into structures which solidify outside the mouth. Amorphous materials such as waxes and resins appear solid but actually are supercooled liquids that flow or plastically deform very slowly under small stresses. Finally there are materials which are used as liquids, e. g., prophylactic pastes, dentifrices, and enamel etching solutions and gels. The ways in which these materials deform or flow when subjected to stress are quite important to their use in dentistry.

Knowledge of flow characteristics of blood under normal conditions enables to establish the effect of abnormal flow conditions such as stenosed valves and hardened arteries on the behavior of blood.

The study of the deformation and the flow of matter, for example, the flow of blood through the heart and blood vessels or the flow of the dental materials, is subject of rheology.

3.1. RHEOLOGICAL CHARACTERISTICS OF LIQUIDS AND DENTAL MATERIALS

Let us consider the basic rheological characteristics of liquids.

The flow of a liquid can be of two types: laminar and turbulent flow.

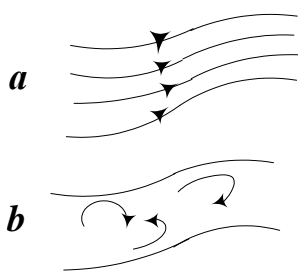

Fig. 3.1. Laminar (a) and turbulent (b) flow of liquid

The flow of a liquid is said to be laminar or orderly or steady flow, if the liquid particles move along fixed paths known as stream lines (fig. 3.1, a). In this case the velocity of particles passing through a given point on a stream line is same as that of the previous particles. In such a flow the velocity of flow at each point is constant both in magnitude and direction though it may change from point to point.

Stream line flow occurs only when the velocity of liquid is below a certain limiting value, known as critical velocity of the liquid. When velocity of flow becomes more than the critical velocity, the flow becomes turbulent or unsteady. In this case mixing of fluid layers and the appearance of eddies occurs (fig. 3.1, b). The velocity of all the particles of liquid passing through the same point therewith may be different.

Here the velocity of the particles v is the linear flow velocity. At the uniform flow $v = \frac{L}{t}$, where L is the distance particles move, t is time of it takes to cover this distance.

Further we will consider the case when the flow of a liquid is smooth and laminar.

Consider a liquid moving over a fixed horizontal surface AB (fig. 3.2). The layer of liquid in contact with the plane AB is at rest while the velocity of flow increases with the distance from fixed surface AB .

Isaac Newton was the first to show that a frictional force F_f acts between different layers of fluid when they move relative to each other. The given force is tangent to the fluid layers and is defined as follows

$$F_f = \eta \cdot S \cdot \frac{dv}{dx}, \quad (3.1)$$

where S is a contact area of the layers, $\frac{dv}{dx}$ the velocity gradient. The magnitude of this gradient is a characteristic of the fluid and it indicates how fast

the velocity changes from a layer to layer. The constant η is called the coefficient of viscosity or simply viscosity (or dynamic viscosity). Viscosity is a measure of the internal resistance to the flow of a fluid which is subject to the shear deformation (fig. 3.2). The concept of viscosity is familiar to anyone who has compared the flow properties of water with those of oil.

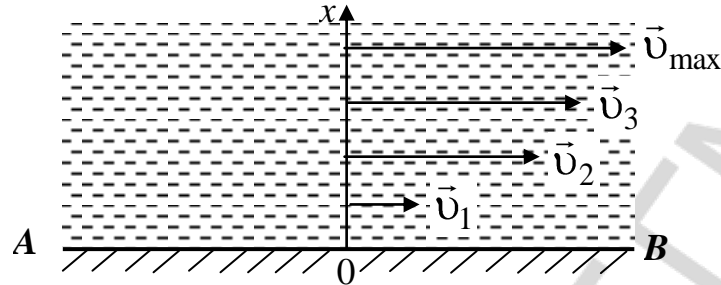

Fig. 3.2. The illustration of the viscous fluid flow

The viscosity is temperature dependent.

In SI system unit of viscosity is the pascal-second $\frac{N \cdot s}{m^2} = Pa \cdot s$. Another unit for viscosity is the poise (P), named after Jean Louis Marie Poiseuille: $1 Pa \cdot s = 10 P$, $1 mPa \cdot s = 10^{-2} P = 1 cP$ (centipoise).

For example, pure water has a viscosity of $1.0 mPa \cdot s$ at $20^\circ C$, and $0.3 mPa \cdot s$ at $100^\circ C$. The viscosity of blood is approximately $4 mPa \cdot s$ ($37^\circ C$) and of blood plasma is approximately $1.2 mPa \cdot s$ ($37^\circ C$).

As far as $\frac{F_f}{S} = \tau$, where τ is the shear stress, and $\frac{dv}{dx} = \dot{\gamma}$ is the rate of change of shear strain which is also called the strain rate or the shear rate, the formula (3.1) can be written as

$$\tau = \eta \dot{\gamma}. \tag{3.2}$$

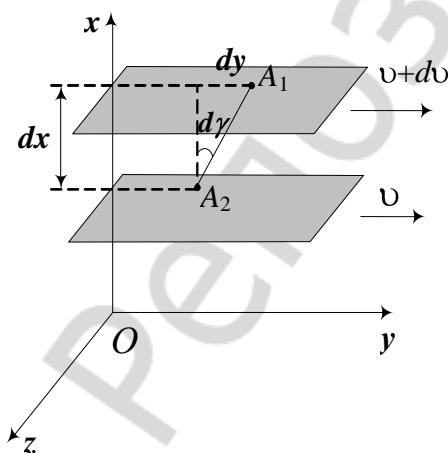

Fig. 3.3. The shear strain upon the viscous fluid flow

The equivalency of the formulas (3.1) and (3.2) is illustrated by the fig. 3.3. From fig. 3.3 it follows that the angle of shear $d\gamma = \frac{dy}{dx} = \frac{dv \cdot dt}{dx}$. Then the shear rate is equal to

$$\text{the velocity gradient } \dot{\gamma} = \frac{d\gamma}{dt} = \frac{dv}{dx}.$$

As stated in Part 1, the shear stress of a solid is proportional to the shear strain (formula (1.6)). However in case of a fluid the shear strain increases continuously and without any limit as long as the stress is

applied. In this case the stress depends not on the shear strain, but on *the rate of its change* (formula (3.2)).

Fluids that are described by the equations (3.1) and (3.2) are called Newtonian fluids. Newtonian fluid has a constant viscosity that does not depend on the shear rate.

Many fluids are non-Newtonian.

Non-Newtonian fluids are characterized by more complicated relationship between the shear stress and the shear rate (the velocity gradient) than the simple linear one in accordance with Newton's law of viscosity.

At present the following types of fluids are distinguished in rheology:

Newtonian: fluids which have constant viscosity, for example, water, most of organic solvents.

Shear thickening (otherwise they are called dilatant): viscosity increases with increasing the shear rate.

Shear thinning (a pseudoplastic matter): viscosity decreases with increasing the shear rate. Many dental materials and blood exhibit pseudoplastic behavior.

Plastic: materials behave like a rigid body until some minimum value of the shear stress τ_0 is reached.

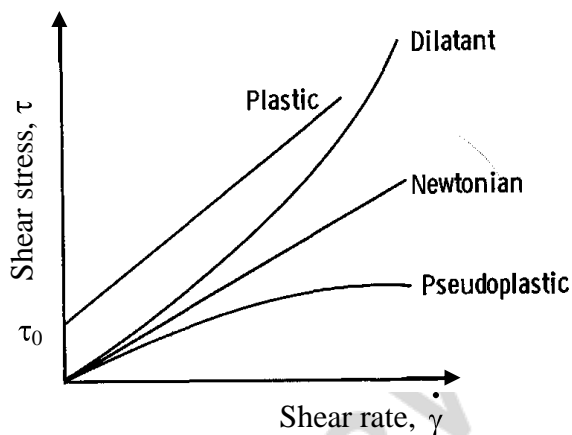

Fig. 3.4. Shear stress versus shear rate for fluids exhibiting different types of rheological behavior

The dependence of the shear stress on the shear rate (curves of fluids) for the above types of fluids is shown in fig. 3.4.

The viscosity of most liquids decreases rapidly with increasing temperature. Viscosity may also depend upon previous deformation of the liquid; such liquids are referred to as thixotropic. Latex paints designed for ceilings and dental prophy pastes are usually thixotropic. If these are stirred

rapidly and the viscosity is measured, a lower value is obtained than that for a sample that has been left undisturbed for several hours.

The viscosity of a dental material may determine its suitability for a given application. Likewise, the nature of the shear stress-strain rate curve can be important in determining the best way of manipulating a material. The viscosity as a function of time can also be used to measure the working time of a material that undergoes a liquid-solid transformation.

Creep, flow. Engineers who design structures to withstand both stress and high temperature are faced with the rheological behavior of solid materials. If a metal is held at a temperature near its melting point and is subjected to

a constant applied force, the resulting strain will be found to increase as a function of time. This time-dependent plastic deformation is referred to as *creep*.

Static creep is the time-dependent deformation produced in a completely set solid subjected to a constant stress. *Dynamic creep* refers to this phenomenon when the applied stress is fluctuating, such as in a fatigue-type test.

Most metals used in dentistry have melting points that are much higher than mouth temperature and thus are not susceptible to the creep in dental application. The most important exception is dental amalgam, which has components with melting points only slightly above room temperature. Since creep produces continuing plastic deformation, the process can be very destructive to a dental restoration.

A somewhat synonymous term is *flow*. Let us recall that the term flow was used in the discussion of rheological behavior of liquids and will now be applied to amorphous materials, which is not surprising in consideration of their structure. Pitch is a good example of such a substance; it will fracture under a sudden blow, but if it is placed in a leaky container it will flow through the leak under its own weight. Glass tubing will slowly deform if it is leaned against the wall or if it is laid with supports at either end.

The term flow, rather than creep, has generally been used in dentistry to describe the rheology of amorphous materials, such as waxes. Although creep or flow may be measured under any type of stress, compression is usually deployed while testing of dental materials. A cylinder of prescribed dimensions is subjected to a given compressive stress for a specified time and temperature. The creep or flow is measured as the percentage of shortening in length that occurs under these testing conditions.

Creep requires an attentive consideration for any dental material that is supposed to be held at a temperature near its melting point for an extended period of time.

Viscosity of plasma and whole blood. The whole blood consists of formed elements that are suspended in plasma. The plasma is a dilute electrolyte solution containing about 8 percent by weight of three major types of proteins (fibrinogen, globulin and albumin) in water. About 45 percent of the volume consist of formed elements and about 55 percent consist of plasma in the normal human blood. The formed elements in blood consist of 95 % red blood cells, 0.13 % white blood cells and about 4.9 % platelets. The white blood cells, also known as leucocytes consist of monocytes, lymphocytes, neutrophils, eosinophils, and basophils.

The majority of the formed elements are red blood cells and the measure of the volume percent of formed elements blood is referred to as *the hematocrit*.

The viscosity coefficient of human plasma ranges between 1.1 and 1.6 mPa·s (1.1 and 1.6 centipoise). Some experiments have suggested that mammalian plasma behaves like a non-Newtonian fluid. On the other hand, several other works have suggested that plasma is Newtonian liquid. It is generally believed that the plasma behaves as a Newtonian fluid with a constant viscosity of 1.2 mPa·s (1.2 cP) at 37 °C, which is the human body temperature. In comparison, the viscosity coefficient of water is 1 mPa·s (1 cP). The presence of plasma proteins results in the higher viscosity compared to that for water.

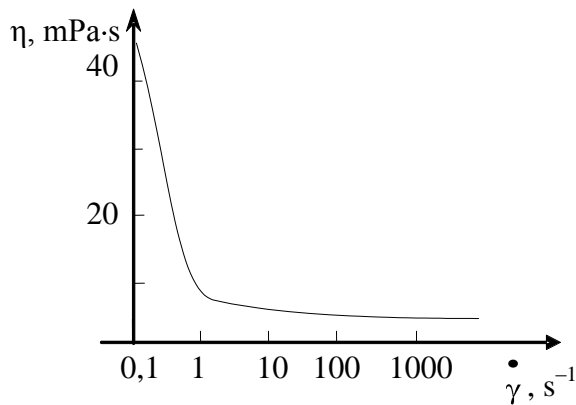

Fig. 3.5. The dependence of the viscosity of whole blood on the shear rate

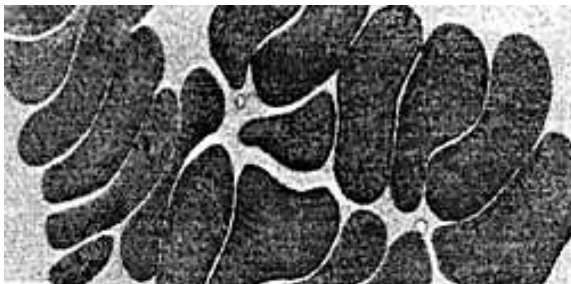

Fig. 3.6. The aggregation of the red blood cells (SEM image)

The dependence of the viscosity of whole blood on the shear rate is shown in fig. 3.5. The data indicate a non-linear (non-Newtonian) behavior of whole blood. This fact can be explained as follows. At low rates of shear, the red blood cells tend to aggregate (fig. 3.6) and thus exhibit an increase in viscosity. As the rate of shear increases, the aggregates gradually break and the viscosity decreases. The viscosity coefficient approaches a constant value of about 4.0 mPa·s (4.0 cP) at the shear rate of approximately 100 s⁻¹. Thus, when specifying the viscosity coefficient of blood, it is important to point out the rate of shear at which the measurements were obtained. Account must be taken of share rate differences in various segments of human circulatory system. Accordingly,

the viscosity of blood can also have different values.

At pathologies the viscosity values of blood ranging from 1.7 to 23 mPa·s (1.7 to 23 cP).

As discussed above, the rate of shear has a profound effect on the measured viscosity of whole blood. Let us consider other factors effecting the viscosity of blood.

Effect of hematocrit. The hematocrit for normal human blood varies between 40 and 45 percent. The viscosity of blood increases (decreases) with increase (decrease) hematocrit.

Effect of temperature. As pointed out above, the viscosity of Newtonian fluid decreases with the temperature increase. This correlation does not always hold for blood. The temperature increase may lead to increase an activity of

such a protein as fibrinogen. It stimulates a formation of the red blood cell aggregates (fig. 3.6), resulting in the blood viscosity increase.

Effect of CO₂ content in blood. Viscosity of blood increases with the increase of the carbon dioxide (CO₂) content in it. Therefore viscosity of vein blood is larger than that of arterial one. This is due to the change in the volume and shape of the red blood cells in vein vessels in comparison to arterial vessels.

3.2. BLOOD FLOW IN HUMAN CIRCULATORY SYSTEM

Blood is a liquid tissue and the simplest analogy to blood flowing in an artery or vein is steady fluid flow through a tube.

Viscous flow in a cylindrical tube. Poiseuille's law. Consider a laminar viscous flow of fluid through a pipe of constant radius R and length L during the time t (fig. 3.7).

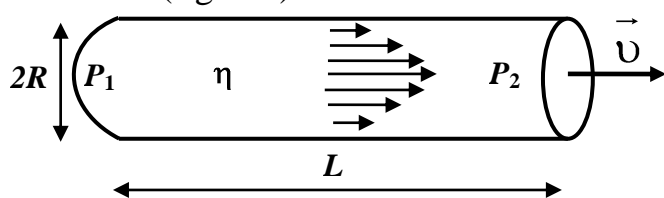

The velocity profile is shown in fig. 3.7. Velocity value u is zero at the walls and a maximum at the center. Therefore the term «the average velocity» is in common usage.

Fig. 3.7. Flow of viscous fluid through the pipe

Our problem is to determine the volume flow rate Q . The volume flow rate is the volume of fluid V which passes through a given surface per time

unit: $Q = \frac{V}{t}$. The unit of Q is $\frac{m^3}{s}$.

In 1840 French doctor and a physicist Jean Louis Marie Poiseuille found that the volume flow rate of a liquid (Q) through a pipe:

1) is directly proportional to the pressure difference between two ends of the pipe Δp :

$$Q \sim \Delta p = p_1 - p_2;$$

2) is directly proportional to the fourth power of the radius of the pipe R :

$$Q \sim R^4;$$

3) is inversely proportional to the length of the pipe L :

$$Q \sim \frac{1}{L};$$

4) is inversely proportional to the coefficient of viscosity of the liquid η :

$$Q \sim \frac{1}{\eta}.$$

Combining one can obtain $Q \sim \frac{\Delta p R^4}{\eta \cdot L}$,

or
$$Q = \frac{\pi \Delta p R^4}{8 \eta \cdot L}, \quad (3.3)$$

where $\frac{\pi}{8}$ is the constant of proportionality. Formula (3.3) is known as

Poiseuille's law. Note, that $V = Q \cdot t = \frac{\pi \Delta p R^4}{8 \eta \cdot L} \cdot t$, where t is the time of the fluid flow through the pipe.

Poiseuille's law only applies to Newtonian liquids. Nevertheless it is of considerable use in the analysis of the flow of blood in human circulatory system.

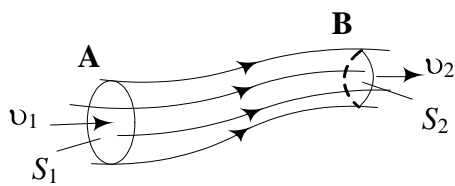

Fig. 3.8. Flow of a liquid through the tube

Equation of continuity. Let us consider flow of a liquid through the tube having area of cross-section S_1 at A and S_2 at B (fig. 3.8). Let v_1 and v_2 are the average velocities of flow through these sections. The volume V_1 of liquid entering the tube at A in time t is $V_1 = S_1 \cdot v_1 \cdot t$.

The volume V_2 of liquid leaving the tube at B in time t is $V_2 = S_2 \cdot v_2 \cdot t$.

Since liquid is incompressible (Poisson coefficient for liquid is equal to 0.5) the volume of liquid entering the tube at A in time t is equal to the volume of liquid leaving the tube at B in the same time ($V_1 = V_2$):

$$S_1 \cdot v_1 \cdot t = S_2 \cdot v_2 \cdot t,$$

where S_1 and S_2 are the areas of cross-section of the tube at A and B, respectively, v_1 and v_2 are linear velocities of flow through these sections.

Consequently, $S_1 \cdot v_1 = S_2 \cdot v_2$, or

$$S \cdot v = \text{const}. \quad (3.4)$$

The equation (3.4) is known as *the equation of continuity of flow* for an incompressible liquid. From the above equation it follows that if at a place, area of cross-section of the tube increases the linear velocity of flow of liquid decreases and vice-versa.

From the analysis of dimensions of S and v it follows that $S \cdot v = Q = \text{const}$.

Velocity of blood flow in the human circulatory system. The circulatory system has two parts: the systemic circulation and the pulmonary circulation (fig. 3.9). The left heart pumps blood into the systemic circulation: organs, muscles, etc. The right heart pumps blood through the lungs. The blood flows from the aorta to several large arteries, to arterioles, and finally to the capillaries, where exchange of oxygen, carbon dioxide, and nutrients with tissues takes place. The blood emerging from capillaries is collected by venules, flows into increasingly larger veins, and finally to the heart through

the vena cava. The heart then pumps the blood through the blood vessels in the lungs. In the lungs carbon dioxide is released from the blood and replaced with oxygen.

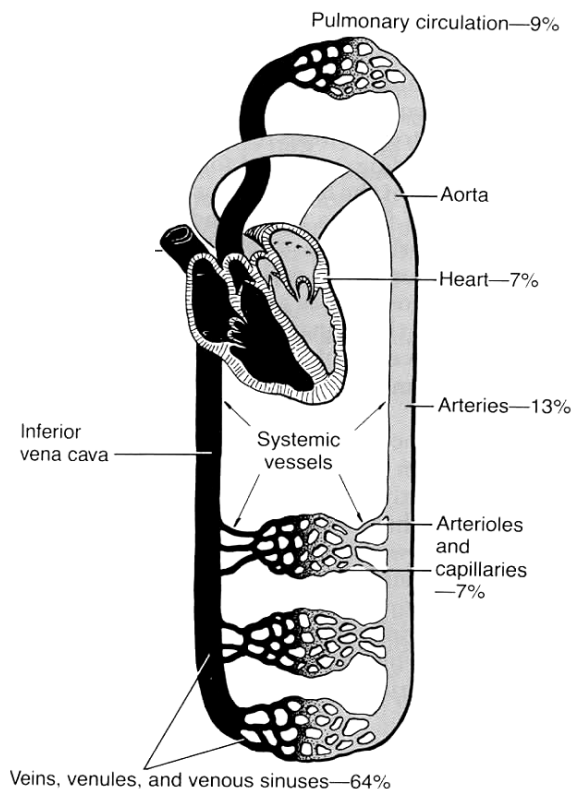

Fig. 3.9. The human circulatory system

a factor of approximately 800. Thus the values of velocity of blood flow in aorta falls in the range 0.5–1 m/s, and for the capillaries $v \approx 1$ mm/s. Changes of the values of S and v for different segments of circulatory system is shown in fig. 3.10.

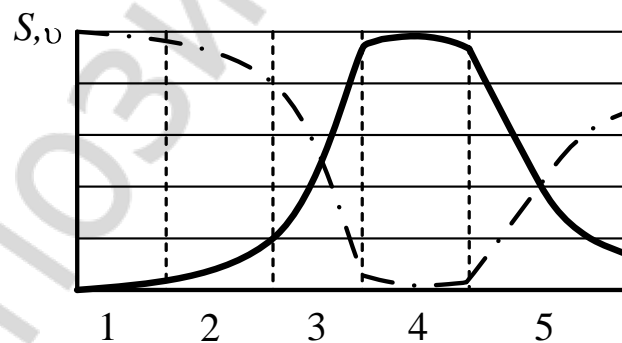

Fig. 3.10. The relationship between the total area of vessel cross-section (S) (solid line) and linear velocity of the blood flow (v) in corresponding vessels (dashed line):

1 — aorta; 2 — arteries; 3 — arterioles; 4 — capillaries; 5 — veins.

Pressure drop in the human circulatory system. Let us define the vascular resistance X in a segment of the circulatory system as the ratio of pressure difference across the segment to the volume flow rate through it:

$$X = \frac{\Delta p}{Q}. \quad (3.6)$$

From Poiseuille's law (3.3) it follows that

$$X = \frac{8\eta L}{\pi R^4}. \quad (3.7)$$

In SI system the unit of X is $\frac{\text{Pa} \cdot \text{s}}{\text{m}^3}$.

In the vascular system branching of vessels often occurs. Therefore let us consider a calculation of total vascular resistance for two certain cases (fig. 3.11).

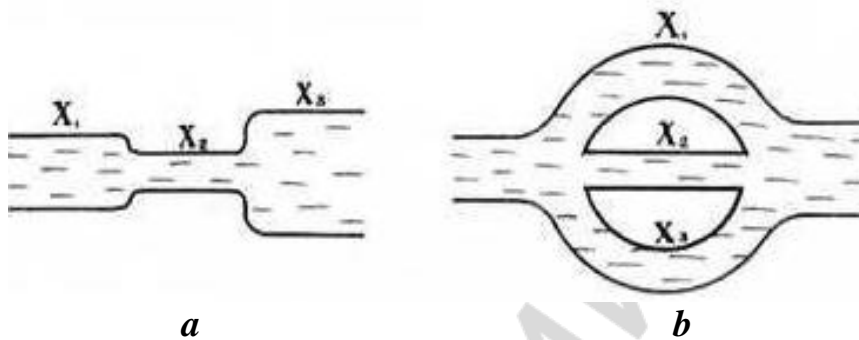

Fig. 3.11. Scheme of a sequent (a) and parallel (b) connection of vessels

If vessels of different diameters are connected in series so that the volume flow rate Q is the same through each one, then the total resistance is the sum of the resistances of each vessel. In the case shown in fig. 3.11, *a* the total resistance is given by: $X_{\text{total}} = X_1 + X_2 + X_3$.

If there is branching so that several vessels are in parallel (fig. 3.11, *b*) the total resistance is given by the formula: $1/X_{\text{total}} = 1/X_1 + 1/X_2 + 1/X_3$.

For the most part, the capillaries are arranged in parallel. Even though the resistance of an individual capillary is large because of its small radius according to the formula (3.7), the resistance of the capillaries as a whole is relatively small (fig. 3.12).

From fig 3.12 it is seen that the resistance value peaks for the set of arteriols. Total resistance of the capillaries is well less than that of arteriols. The resistance of veins is still less, modest values of the resistance are characteristic of aorta and large arteries.

Since $Q = \text{const}$, then by the equation (3.6), it is precisely the vascular resistance value X in various circulatory system segments that determines the distribution of the blood pressure drop in the human circulatory system (fig. 3.13).

From fig. 3.13 it is seen that, the pressure drop in aorta and large arteries is small (see dashed line in ranges 1, 2 of the given figure). *The maximum value*

of pressure drop is observed for arterioles since precisely for them the resistance peaks (fig. 3.12).

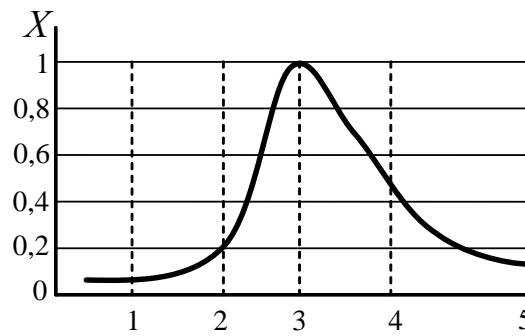

Fig. 3.12. Vascular resistance of different circulatory system segments:
1 — aorta; 2 — arteries; 3 — arterioles; 4 — capillaries; 5 — veins

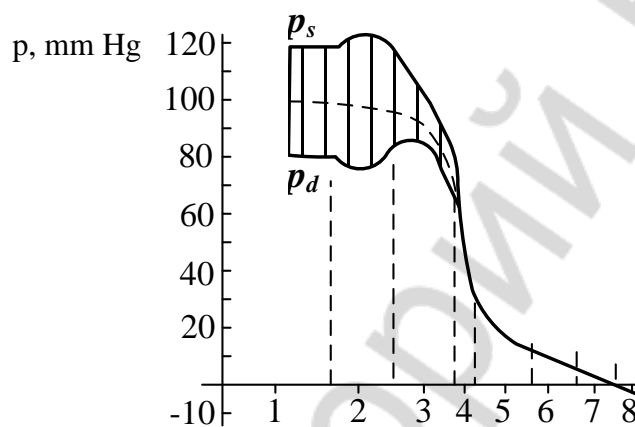

Fig. 3.13. The distribution of the blood pressure in different systemic vessels:
1 — aorta; 2 — large arteries; 3 — small arteries; 4 — arterioles; 5 — capillaries; 6 — venules;
7 — veins; 8 — vena cava

It is also evident from fig. 3.13 that the blood pressure in aorta and arteries is not the same during systole and diastole. Blood pressure is maximum during systole, when ventricles contract and force the blood into the pulmonary artery and aorta. It is minimum during diastole, when the ventricles relax and they begin to fill with blood again. Therefore the systolic (maximum) and the diastolic (minimum) pressure are distinguished. Corresponding pressure values are denoted by p_s и p_d .

For large vessels the average blood pressure p_{av} value is in common usage, which is marked by dashed line in fig. 3.13. For aorta and large arteries it is defined by $p_{av} = p_d + 1/2(p_s - p_d) = (p_s + p_d)/2$, and for peripheral arteries: $p_{av} = p_d + 1/3(p_s - p_d)$. The difference $(p_s - p_d)$ is termed the pulse pressure p_{pulse} , its magnitude is shown in fig. 3.13 by vertical lines.

Blood pressure is normally expressed in units of millimeter of mercury (torr) (mm Hg). For a healthy young man the blood pressure in aorta $p_s \approx$

120 mm Hg, $p_d \approx 80$ mm Hg, $p_{av} \approx 100$ mm Hg, $p_{pulse} \approx 40$ mm Hg (1 mm Hg = 133.3 Pa).

Typical values of the average pressure, the average velocity of blood flow in certain branches, and vessel sizes at different generations of branching are given in table 3.1.

Table 3.1

Typical values for the average pressure at the entrance to each generation of the major branches of cardiovascular tree, the average velocity of blood flow in certain branches, and dimensions of the vessels

Location	Average pressure, mm Hg	Diameter, mm	Wall thickness, mm	Average velocity, m/s
Aorta	100	20	2.00	0.480
Arteries	95	4	1.00	0.450
Arterioles	86	0.05	0.20	0.05
Capillaries	30	0.008	0.001	0.001
Venules	10	0.02	0.002	0.002
Veins	4	5	0.5	0.010
Vena cava	3	30	1.5	0.380

The work and power of the heart. The work done in one cardiac cycle (systole) A is defined by:

$$A = A_{\text{left}} + A_{\text{right}}, \quad (3.8)$$

where A_{left} is the work done by left ventricle, A_{right} is the work done by right ventricle.

It is known that $A_{\text{right}} = 0.2 A_{\text{left}}$, then the value of A is:

$$A = A_{\text{left}} + 0.2 A_{\text{left}} = 1.2 A_{\text{left}}. \quad (3.9)$$

Let us calculate the work done by left ventricle in one cycle. Static component of this work A_{st} is defined by the formula:

$$A_{\text{st}} = p_{\text{av}} \cdot V_s, \quad (3.10)$$

where p_{av} is the average blood pressure in aorta, typically $p_{\text{av}} \approx 100$ mm Hg (13.3 kPa); V_s is the systolic (stroke) volume. This is the volume of blood ejected by ventricle at each beat, $V_s \approx 70$ ml for an adult man at rest.

In accordance with the formula (3.10) A_{st} of the left ventricle is equal to $13.3 \cdot 10^3 \text{ Pa} \cdot 70 \cdot 10^{-6} \text{ m}^3 \approx 0.9 \text{ J}$.

The kinetic component of the work A_k is defined by the formula:

$$A_k = \frac{m v^2}{2} = \frac{\rho V_s \cdot v^2}{2}, \quad (3.11)$$

where ρ is the blood density ($\rho \approx 10^3 \text{ kg/m}^3$); v is the blood flow velocity in aorta ($v \approx 0.5 \text{ m/s}$).

$$\text{Then } A_k = \frac{1}{2} \cdot 10^3 \text{ kg/m}^3 \cdot 70 \cdot 10^{-6} \text{ m}^3 \cdot 0.25 \text{ m}^2/\text{s}^2 \approx 0.01 \text{ J}.$$

The total work done by the left ventricle at rest is $A_{\text{left}} \approx 0.9 \text{ J} + 0.01 \text{ J} = 0.91 \text{ J}$.

Thus, in accordance with the formula (3.9), the work done at one cardiac cycle at rest is equal to approximately 1 J ($A = 1.2 A_{\text{left}} = 1.2 \cdot 0.91 \text{ J} \approx 1 \text{ J}$).

Assuming that the heart does one contraction per second, the work done by heart daily is equal to 86400 J.

The work is done during systole, which lasts 0.3 s. Therefore the heart power is $N = \frac{A}{t} \approx \frac{1 \text{ J}}{0.3 \text{ s}} = 3.3 \text{ W}$.

3.3. METHODS OF VISCOSITY MEASUREMENTS

Viscometer is an instrument which is used for measuring the viscosity of a fluid.

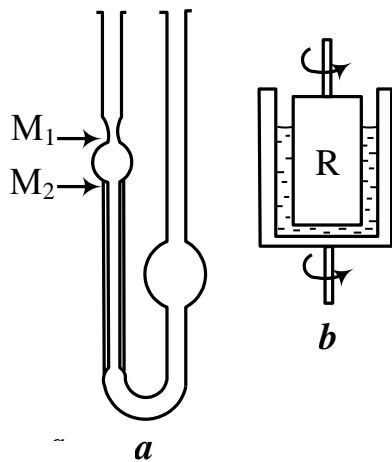

Fig. 3.14. The Ostwald (a) and coaxial cylinder (b) viscometers

Two basic types of viscometers that will be discussed are: 1) capillary viscometer; 2) coaxial cylinder viscometer.

Capillary viscometer is based on the principle that the viscosity of the liquid can be determined from measurements of the time required for the certain volume of the fluid to pass through the capillary. The most frequently used is *the Ostwald viscometer* (fig. 3.14, a). The parameter under measurement is the time taken for the meniscus of a liquid to pass between marks M_1 and M_2 . This parameter is proportional to the viscosity. In this method the time t for the fluid under study is compared to the time t_0 for the standard fluid. The

viscosity of standard fluid is given.

The formula for determining the viscosity η immediately follows from Poiseuille's law:

$$\eta = \eta_0 \frac{\rho t}{\rho_0 t_0}, \quad (3.12)$$

where η_0 is the viscosity of the standard fluid; ρ_0 density of the standard fluid; ρ is the density of the fluid under study.

Rotational viscometers are particularly useful in analyzing the viscosity behavior of non-Newtonian fluids. The same sample of the fluid can be used to study the behavior at different rates of shear. Fig. 3.14, b shows a simple coaxial cylinder rotational viscometer.

In the case of the coaxial viscometer, the test fluid is placed in the space between two cylinders (R is a radius of inner cylinder) (fig. 3.14, b). If one of the cylinders is rotated at a constant speed (ω rad/s) around the axis as pointed in fig. 3.14, b then the torque M will act on the other cylinder. The parameter under measurement is the torque which is proportional to the viscosity of

the fluid. It is assumed that the flow of the fluid between the cylinders is steady and laminar.

The viscosity of the fluid can be derived by the expression:

$$\eta = \frac{M}{k\omega}, \quad (3.13)$$

where k is the constant for a device, ω is the rotational speed of a cylinder.

The shear rate will change upon changing the value of a rotational speed. Therefore this viscometer allows measuring the dependence of the fluid viscosity on the shear rate.

PART 4. PHYSICAL BASIS OF ADHESION. CURRENT ADHESIVE SYSTEMS IN DENTISTRY

The phenomenon of adhesion is involved in many situations in dentistry. It is a principal concern in solving the problem of leakage around dental restorative materials, for example.

The retention of artificial dentures is probably dependent to some extent at least upon adhesion both between the denture and saliva and between the saliva and the soft tissue. Certainly the attachment of plaque or calculus to tooth structure is partially an adhesive mechanism. Therefore, an understanding of the fundamentals associated with the phenomenon is important to the dentist.

When two substances are brought into intimate contact with each other, the molecules of one substance adhere to molecules of another.

The force of attraction between the molecules of the different substances is called the force of adhesion.

The force of attraction between the molecules of the same substance is called the force of cohesion.

The material or film added to produce the adhesion is known as *the adhesive*, and the material to which it is applied is called *the substrate (the adherend)* (fig. 4.1).

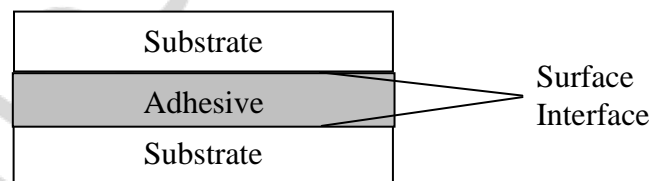

Fig. 4.1. Adhesive joint

Thus the adhesion is the phenomenon which involves some type of intermolecular attraction between the adhesive and the substrate.

Let us consider the main factors affecting the capacity of substances to form a strong adhesive joint.

4.1. FACTORS AFFECTING ADHESION

Surface tension. For adhesion to exist, the surfaces must be attracted to one another at their interface. Such a condition may exist regardless of the phases (solid, liquid, or gas) of the two surfaces, with the exception that the adhesion between two gases is not to be expected.

It is a common knowledge that when a small quantity of mercury is poured on a wooden table, it splits up into small and big drops. Small drops will always be spherical since for a given volume sphere has the least surface area. If such a drop is pressed gently with a finger, it becomes flat but regains the spherical shape when a finger is removed. In this respect the drop behaves like a rubber balloon. If an iron needle is gently placed on the water surface it floats though its density is approximately 9 times more than that of water. The surface of water below the needle is slightly depressed and supports the needle just as a stretched rubber membrane will do. These facts are attributed to a property of liquid, known as *surface tension*.

Thus the surface tension is property of a liquid by the virtue of which its free surface at rest behaves like an elastic skin or stretched rubber membrane with a tendency to contract so as to occupy minimum surface area.

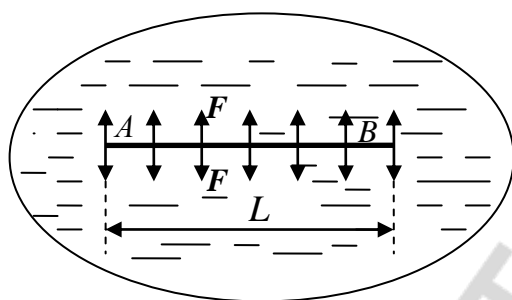

Fig. 4.2. A representation of surface tension of the liquid

Imagine a line AB drawn on the liquid surface as shown in fig 4.2. The surface on either side of this line exerts a pulling force on the surface on the other side. This force lies in the plane of the surface and is at right angles to the line AB . The magnitude of such force per unit length L of the line is the measure of the surface tension.

Thus the surface tension is measured as the force F acting normally, per unit length L on an imaginary line drawn on the free liquid surface (fig. 4.2). (The force is tangential to the liquid surface). It is represented by the symbol σ :

$$\sigma = \frac{F}{L}. \quad (4.1)$$

The units for surface tension in SI system are newtons per meter: $\frac{N}{m}$.

Molecular theory of the surface tension. Let us consider, for example, the liquid-gas interface (fig. 4.3). If a molecule is brought from interior to the surface film¹, an extra work is to be done against this cohesive force. This work done is stored as additional potential energy of the molecules in the surface film. Thus the potential energy of the molecules in the surface film is greater than that of the molecules in the interior of the liquid. This extra

¹ Surface film is a layer of liquid having thickness equal to molecular range.

potential energy of the liquid molecules W in the unit area of the surface film S is called the *surface energy or the surface tension* σ .

$$\sigma = \frac{W}{S}. \quad (4.2)$$

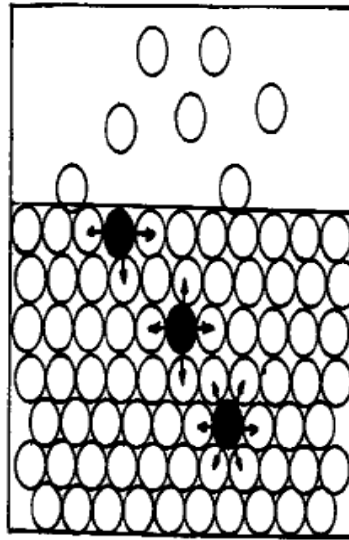

Fig. 4.3. A representation of liquid-gas interface

From the equation (4.2) it follows that the units for the surface tension are Joules per square meter: $\sigma = \frac{J}{m^2}$. It is easily to show that the above mentioned units for the surface tension are exactly the same since 1 Joule = 1 N·m, and $\sigma = \frac{J}{m^2} = \frac{N \cdot m}{m^2} = \frac{N}{m}$.

The surface tension of some substances is given in table 4.1.

Table 4.1

Surface tension of some substances

Substance	Temperature, °C	σ , N/m
Water	20	0.073
Mercury	20	0.465
Olive oil	18	0.035
Silver	970	0.800
Gold	1070	1.000
Copper	1130	1.100

It is law of nature that every system tends to occupy a position of least potential energy; because that is most stable. In order to attain minimum of the potential energy and hence a stable equilibrium, the surface film also tends to contract to minimize its surface area so that the number of molecules in the film may be minimum. Thus the free surface of a liquid should have a tendency to have minimum area.

Liquid in small quantity has a spherical shape because for a given volume, a sphere has minimum surface area.

The tendency of a soap film to contract and drops of a liquid to form spherical shapes due to surface tension can be understood as the principle of the system achieving a state of the lowest energy by minimizing its surface area.

The surface atoms of a solid tend to form bonds to other atoms that come into close proximity to the surface in order to reduce the surface energy of the solid. As pointed out above, this attraction across the interface for unlike molecules is called adhesion. For example, molecules in the air may be attracted to the surface and be adsorbed by the material. Silver, platinum, and gold adsorb oxygen readily. With gold, the bonding forces are of the secondary type, but in case of silver, the attraction may be by chemical or primary bonding, and silver oxide may form.

When primary bonding is involved, the adhesion is termed chemisorption, as compared with physical bonding by van der Waals forces. In chemisorption, a chemical bond is actually formed between the adhesive and the adherend. An example of this type of adhesion is an oxide film formed on the surface of a metal. Van der Waals forces are weaker than primary bonding since they are intermolecular rather than intramolecular.

Van der Waals forces invariably precede chemisorption. Then, as the distance between the adhesive and the adherend diminishes, primary bonding may become effective. However, chemisorption is limited to the monolayer of the adhesive present on the adherend.

The surface energy and, therefore, adhesive properties of a given solid can be reduced by any surface impurity, such as gas adsorption or oxidation as previously described. The functional chemical groups available or even the type of crystal plane of a space lattice present at the surface may also affect the surface energy.

In summary, *the greater the surface tension (surface energy), the greater will be the capacity for adhesion.*

Wetting. It is very difficult to force two solid surfaces to adhere. Regardless of how smooth their surfaces may appear, they are likely to be very rough when they are viewed at the atomic or molecular dimensions. Consequently, when they are placed in apposition, only the «hills» or high spots are in the contact. Since these areas usually constitute only a small percentage of the total surface, no perceptible adhesion takes place. *The attraction is generally negligible when the surface molecules of the attracting substances are separated by the distances greater than 1 nm.*

One method of overcoming this difficulty is to use a fluid that will flow into these irregularities and thus provide contact over a great part of the surface of the solid. For example, when two polished glass plates are placed one on top

of the other and are pressed together, they exhibit little tendency to adhere for reasons previously described. However, if a film of water is introduced between them, considerable difficulty is encountered in separating the two plates. The surface energy of the glass is sufficiently great to attract the molecules of water.

To produce adhesion in this manner, the liquid must flow easily over the entire surface and adhere to the solid. *This characteristic is referred to as wetting.* If the liquid does not wet the surface of the substrate, the adhesion between the liquid and the substrate will be negligible or nonexistent. If there is a true wetting of the surface, adhesion failures cannot occur. Failure in such cases actually occurs cohesively in the solid or in the adhesive itself, not in the interface where the solid and adhesive are in contact.

The ability of an adhesive to wet the surface of the adherend is influenced by a number of factors. *The cleanliness of the surface* is of particular importance. A film of water only one molecule thick on the surface of the solid may lower the surface energy of the adherend and prevent any wetting by the adhesive. Likewise, an oxide film on a metallic surface may inhibit the contact of the adhesive.

The surface energy of some substances is so low that few, if any, liquids will wet their surfaces. For example, some organic substances are of this type. Close packing of the structural organic groups and the presence of halogens may prevent wetting. The synthetic resin commercially known as Teflon [poly(tetrafluoroethylene)] is often used in situations in which it is desirable to prevent the adhesion of films to a surface. Metals, on the other hand, interact vigorously with liquid adhesives because of their high surface energy.

In general, the comparatively low surface energies of organic and most inorganic liquids permit them to spread freely on solids of high surface energy. Thus, *formation of a strong adhesive joint requires good wetting.*

Contact angle. If a liquid is dropped on a flat solid surface, then the liquid drop will spread or make a spherical bubble as shown in fig. 4.4.

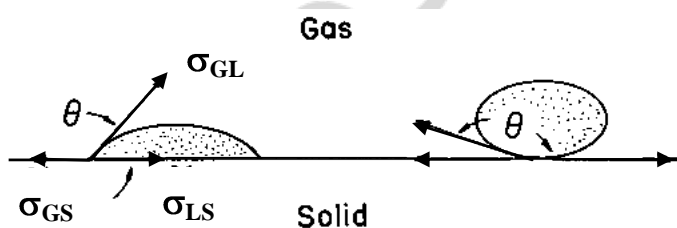

Fig. 4.4. Wetting and non-wetting of a liquid on a flat surface of a solid

The extent to which an adhesive will wet the surface of an adherend may be determined by measuring the so-called *contact angle* θ . The contact angle is the angle a drop of liquid makes with the substrate at their interface (fig. 4.4).

If the molecules of the adhesive are attracted to the molecules of the substrate as much as or more than they are to themselves, the liquid adhesive will spread completely over the surface of the solid, and no angle will

be formed ($\theta = 0^\circ$). Stated differently, the forces of adhesion are stronger than the cohesive forces holding the molecules of the adhesive together. However, if, for example, the energy of the surface of the adherend is reduced slightly by contamination or other means, a small angle may be formed. If a monolayer film of a contaminant were present over the entire surface, a medium angle might be obtained, whereas a very high angle would result on a solid of low surface energy, such as Teflon. Since the tendency for the liquid to spread increases as the contact angle decreases, *the contact angle is a useful measure of spreadability or wettability.*

At equilibrium the surface tension among the three phases at the solid plane should be zero because the liquid is free to move until force equilibrium is established (fig. 4.4); therefore,

$$\sigma_{GS} - \sigma_{LS} - \sigma_{GL} \cdot \cos\theta = 0,$$

where σ_{GS} , σ_{LS} , σ_{GL} are the surface tensions of the gas-solid interface, liquid-solid interface and gas-liquid interface, respectively.

Hence

$$\sigma_{GS} = \sigma_{LS} + \sigma_{GL} \cdot \cos\theta. \quad (4.3)$$

From equation (4.3) it follows that

$$\cos\theta = \frac{\sigma_{GS} - \sigma_{LS}}{\sigma_{GL}}. \quad (4.4)$$

The wetting characteristics for a given liquid and solid can be generalized as

$\theta = 0^\circ$ — complete wetting

$0^\circ < \theta < 90^\circ$ — partial wetting

$\theta > 90^\circ$ — non-wetting (fig. 4.4).

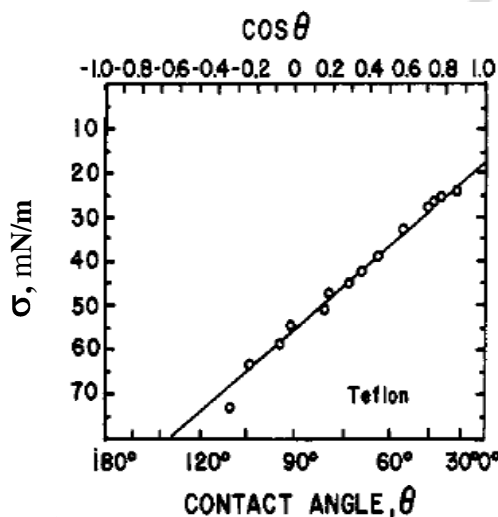

Fig. 4.5 A Zisman's plot of Teflon®. The contact angles of Teflon® with each of a series of pure liquid are presented (from ref. [3])

Note that equation (4.3) only gives ratios rather than absolute values of the surface tension. However, the contact angle method can be used to measure the critical surface tension of a given liquid and a given solid which is close to the intrinsic surface tension. A series of homologous liquids is used to measure contact angles with the solid and these angles are plotted in a so-called Zisman's plot as shown in fig. 4.5.

Table 1.4 gives some values of contact angles. It follows, then, that the smaller the contact angle, the better able is the adhesive to fill in irregularities in the surface of the substrate. Also, the fluidity of the adhesive influences the extent to which these voids or irregularities are filled.

Contact angle of some materials

Liquid	Substrate	Contact angle
Methylene iodine (CH ₂ I ₂)	Soda lime glass	29°
CH ₂ I ₂	Fused quartz	33°
Water	Paraffin	107°
Mercury	Soda lime glass	140°

Of course, solid «flat» surfaces are not actually planar. Surface imperfections are always a potential hazard in attaining and maintaining an adhesive bond. Air pockets may be created during the spreading of the adhesive that will prevent complete wetting of the entire surface (fig. 4.6). When the adhesive joint is subjected to thermal changes and mechanical stresses, stress concentrations develop around these voids. The stress may become so great that it will initiate a break in the adhesive bond adjacent to the void. The crack so formed may propagate from one void to the next, and the joint may break as if it had a built-in «zipper».

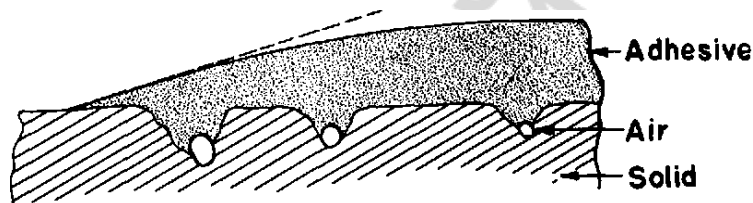

Fig. 4.6 Air pockets created in a surface irregularity

Mechanical Bonding. Strong attachment of two substances can also be accomplished simply by mechanical bonding or retention rather than molecular attraction. Such structural retention may involve such mechanism as a *penetration of the adhesive into microscopic or submicroscopic irregularities (e. g., crevices and pores) in the surface of the substrate*. A fluid or semi-viscous liquid adhesive is best suited for such a procedure, since it readily penetrates into these surface discrepancies. Upon hardening, the multitude of adhesive projections embedded in the adhered surface provides the footholds for mechanical attachment or retention.

The adhesive capacity to penetrate into all cracks and pores in the solid substrate is quantitatively characterized by means of the so-called the penetration coefficient (PC):

$$PC = \frac{\sigma \cos \theta}{2\eta}, \quad (4.5)$$

where σ is the surface tension of the adhesive (to air); η is its viscosity; θ is a contact angle. The penetration coefficient indicates the rate of penetration of a liquid into a capillary space. In most cases the units of PC are cm/s.

From the above formula it follows that the larger σ the better the adhesive penetrates into the substrate.

This mechanism has been commonly used in dentistry, in lieu of adhesives or restorative materials. For example, retention of cast restorations (e. g., a gold crown) is enhanced by mechanical attachment of the cementing agent into irregularities that exist on the internal surface of the casting and those that are present in the adjoining tooth structure.

Etching technique. An improving the performance of the restoration through mechanical bonding may be also achieved by using the resin (plastic) restorative materials. Since these resins do not have the capability of truly adhering to tooth structure, leakage around the restoration poses a major problem. Such leakage patterns contribute to secondary caries and irritation to the pulp.

In order to minimize the danger of penetration of deleterious agents around the restoration, the following technique for placement of such materials has been developed by Buonocore in 1955. Before insertion the resin, the enamel of the adjoining tooth structure is treated with phosphoric acid for a short period of time. This procedure is referred to as the «*etching*» technique. Thus, the acid etching technique is an example of how bonding between a dental material and tooth structure can be attained through mechanical mechanisms, not molecular adhesion.

4.2. CURRENT DENTAL ADHESIVE SYSTEMS AND MECHANISMS OF THEIR BONDING TO HARD TOOTH TISSUES

Factors affecting adhesion to tooth structure. Certain of the fundamentals involved in adhesion can be readily related to dental situations. For example, when contact angle measurements were used to study the wettability of enamel and dentin, it was found that the wettability of those surfaces was markedly reduced following the topical application of an aqueous fluoride solution. Carrying that information into the clinical situation, it was found that the fluoride-treated enamel surface retained less plaque over a given period of time, presumably because of lowered surface energy. Thus, it is not inconceivable that fluorides may be effective in reducing dental caries by providing a tooth surface that stays cleaner longer, in addition to the recognized mechanisms of reducing the enamel acid solubility.

In the same vein, because of the higher surface energy of many restorative materials compared with the tooth, there is a greater tendency for the surface and margins of the restoration to accumulate debris. This may in part account for the relatively high incidence of marginal caries seen around dental restorations.

It is worth noting that in certain instances, continuing sensitivity after placement of the restoration, recurrent caries, and deterioration at the margins

of the restoration can be associated with the lack of adhesion between the restoration and the tooth.

It is obvious that the problem of the development of the adhesives are indeed complex. The tooth composition is inhomogeneous. Both organic and inorganic components are present in different amounts in dentin and in enamel. A material that would adhere to the organic portion may not be likely to adhere to the inorganic components, and an adhesive that would bond to enamel would probably not adhere to dentin to the same extent.

After the dentist has prepared the cavity, tenacious microscopic debris covers the enamel and dentin surfaces. This surface contamination reduces wetting. In addition, the instruments used to cut the cavity leave a rough surface. These irregularities act as stress concentrators when the restoration is subjected to masticating forces and to the thermal fluctuations that are always occurring in the oral cavity.

The problem of water is of greatest significance. The inorganic component of tooth structure has a strong affinity for water. In order to remove the water, the enamel and dentin would have to be heated to a temperature unrealistic for the oral cavity. This means that a tooth cannot be safely dried at mouth temperature with the devices and agents which are at the disposal of the dentist. The presence of at least a monolayer of water on the surface of the prepared cavity must be accepted. That water layer reduces the surface energy and thus may reduce the wetting by the adhesive.

In addition, there is fluid exchange through certain components of the tooth. The dental adhesive must displace the water, react with it, or wet the surface better than the water that is already present on and in the tooth structure. Furthermore, it must maintain long-term adhesion in an aqueous environment.

Current dental adhesive systems. Dental adhesives have been developed in order to ensure bonding composite resins to hard tooth tissues. There is no one universal bonding system, but recent advances in the chemistry of these adhesives allow many of them to be bonded to all intraoral substrates — to enamel, to dentin, and to all types of dental resins, ceramics and metals.

When choosing an optimum adhesive system, among so many adhesives used today, dentist should understand the mechanism of their bonding to hard tooth tissues, the peculiarities of their usage, their classification, advantages and disadvantages.

All adhesives used today exhibit the same phenomena for adhesion, i. e. micromechanical locking to the etched enamel prisms and to dentin through hybridization².

² Hybridization in dentistry — a hybrid layer formation after etching and infiltration of hard tooth tissues by the adhesive system components that are polymerized.

The adhesive systems have several classifications [7–9]. According to the mechanism of interaction with tooth structure adhesive systems can be differentiated into two major distinct classes: etch-and-rinse (E&R) (total etch (TE)) and self-etch (SE).

The first clinical step with total-etch adhesive systems is the application of a phosphoric acid directly on the enamel or dentin surface followed by the mandatory rinsing step. The etching prior the adhesive application allows a more efficient and durable bond.

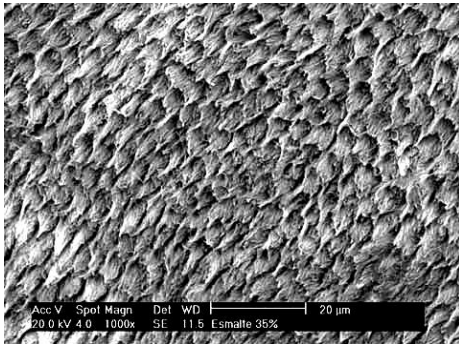

Fig. 4.7. The etched enamel surface (SEM image)

In case of enamel a 20–40 % phosphoric acid is applied on the enamel surface. The etching leads to demineralization of the enamel and creates a microscopically roughened surface with the 10-to-40 micrometer deep microporosities (fig. 4.7).

When a low viscosity adhesive resin is then applied it readily penetrates into the microporosities on the enamel surface forming small «tags». Upon polymerization, there is formed an intermediate layer (10–25 µm) on the enamel surface called a hybrid layer (fig. 4.8). As a result, the adhesive resin provides improved mechanical retention of the composite to enamel.

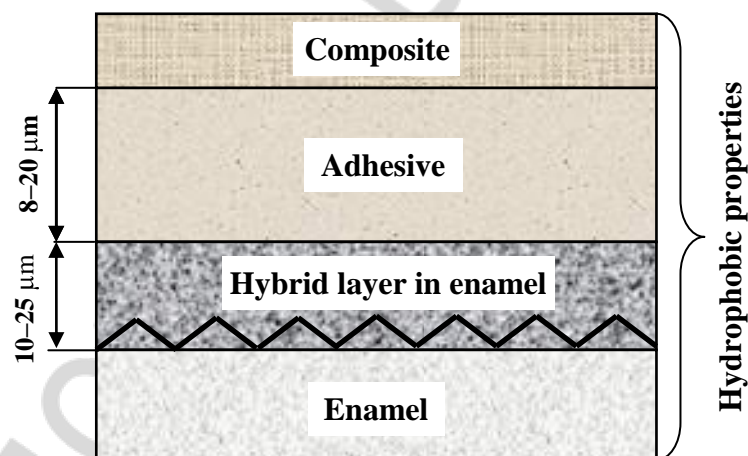

Fig. 4.8. Scheme of the formation of a hybrid layer in enamel

On dentin surface, bonding is a more complex phenomenon, mainly due to the peculiarities of the morphology and composition of dentin [7, 8]. Dentin is a hydrophilic substrate and it can not readily bond to the hydrophobic adhesives. Besides, the presence of a smear layer (2–10 µm), partially occluding dental tubules, also makes dentin bonding more complex than enamel bonding (fig. 4.9, A).

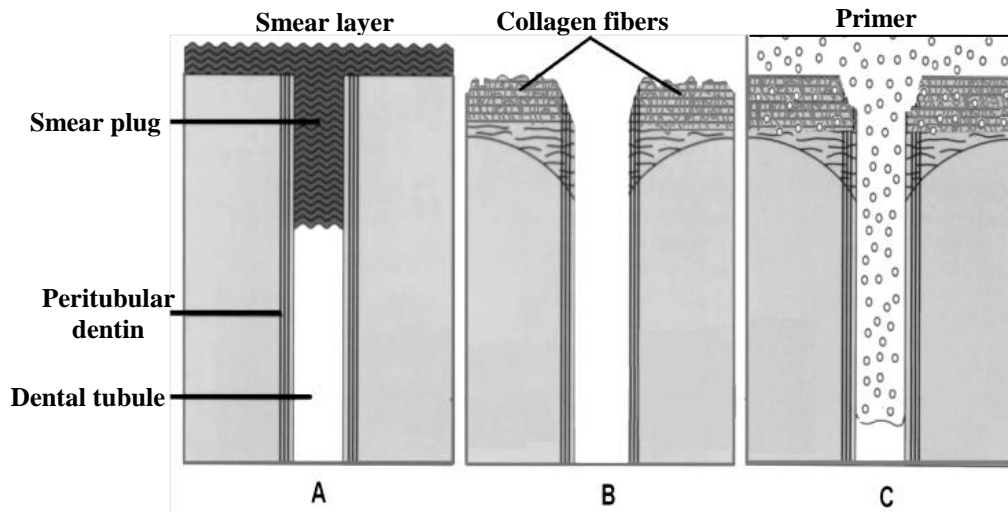

Fig. 4.9. General scheme of etching and priming dentin surface:
 A — dentin surface after preparation, B — etched dentin surface, C — dentin surface after priming

In case of dentin a 10–15 % phosphoric acid and other acids are applied for etching its surface. This allows removing the dentin smear layer and exposure of dental tubules (fig. 4.9, B).

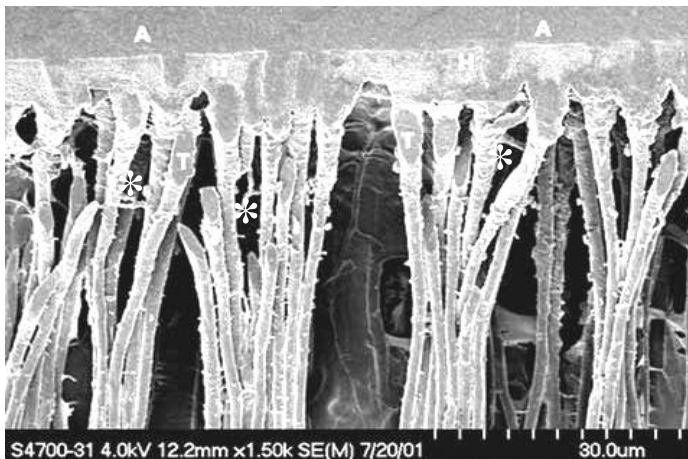

Fig. 4.10. Etch-and-rinse adhesive infiltrated hybrid layer with resin tags:
 A — adhesive, H — hybrid layer, T — resin tags.
 Resin tags show lateral branches (asterisks) [8]

branches is formed, thus creating micromechanical and chemical retention of the resin and dentin (fig. 4.10).

The scheme of the formation of an adhesive bond between composite resins and dentin is shown in fig. 4.11.

With the development of two different classes of bonding systems that relied on the use of phosphoric acid as a surface etchant, the classification and the description of bonding systems based upon generational time-line changes has been developed [8, 9].

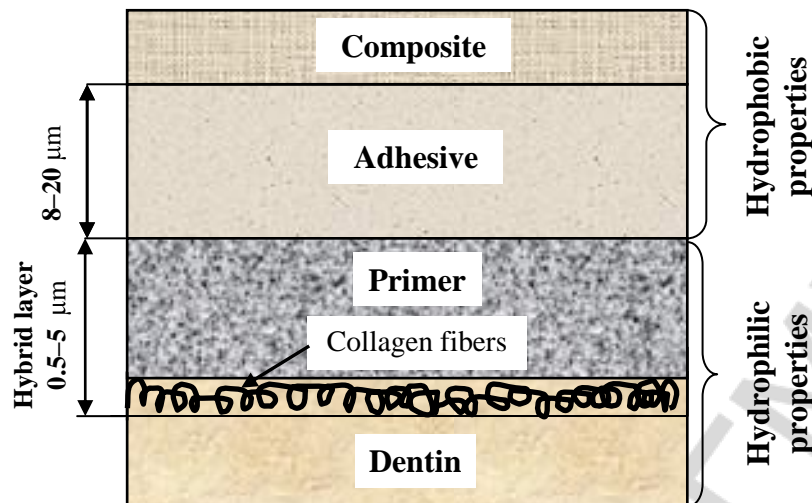

Fig. 4.11. Scheme of the formation of a hybrid layer in dentin

Modern adhesive systems have been developed in the 90s.

Fourth-generation bonding systems were referred to as total-etch multi-bottle (multi-step) systems (also referred to as three-step etch-and-rinse) (3-E&R) (e. g., Solid Bond, Optibond FL, ScotchBond MP). The given systems are held to be «gold standard» in adhesive dentistry. Fourth-generation bonding systems, as a rule, are presented by two bottles: a primer and an adhesive. Technique of their application includes at least three steps: etching, priming and bonding.

Fifth-generation systems were referred to as total-etch single-bottle bonding agents that contain both primer and adhesive (also referred to as two-step etch-and-rinse) (2-E&R) (e. g., Prime & Bond NT, Optibond Solo Plus, One Step Plus, Gluma 2Bond).

Both fourth- and fifth-generation products require a total etch with phosphoric acid before adhesive placement.

The latest achievements are self-etch adhesive systems which were referred to sixth and seven-generation systems where all components for etching, priming and bonding are supplied in a single bottle.

Self-etch adhesive systems are aqueous mixtures of acidic functional monomers, usually phosphoric acid esters with a pH value higher than that of phosphoric acid gels. The SE approach does not require a separate etching step because the etchant is incorporated into the adhesive (either in a separate self-etching primer or in the adhesive). Additionally, the step of rewetting with water is eliminated because SE adhesives contain water and are never completely dried from the tooth. SE adhesives do not remove the smear layer, instead incorporating it into the adhesive. Investigations have demonstrated that SE systems provide hybridization and infiltration of dentin similar to that seen with etch-and-rinse adhesives.

It is worth noting that one of the important factors that affect bonding of adhesive systems to the hard tooth tissues is adding filler particles. It has been found that the addition of fillers to the adhesive systems can in general improve the mechanical properties of the hybrid layer.

Nowadays different kinds of adhesive systems have been developed which are filled with nanoparticles (5–20 nm in size) (Gluma Self Etch, Clearfil SE Bond, AdheSE, Prime&Bond NT, etc.). Nanoparticles are capable to penetrate into the collagen network and dental tubules providing retention of the adhesive to the hard tooth tissues.

Although adhesive systems have been improved greatly over the past decade, there are still problems associated with their usage. Therefore novel adhesive systems and the techniques are continuously being developed.

РЕПОЗИТОРИЙ БГМУ

QUESTIONS

Part 1. Physical properties of dental materials and tissues of tooth

1. Strain. The difference between the elastic and permanent (plastic) deformation. The main types of deformation.
2. Stress, its dimension.
3. Hooke's law. Modulus of elasticity (Young's modulus), its relationship with the stiffness of a material.
4. The shear modulus, Poisson coefficient, the relationship between them.
5. Stress-strain curve. Elastic limit, proportional limit, yield limit, ultimate strength.
6. Resilience, its physical sense and meaning for a proper selection of a dental material.
7. Fatigue. An endurance limit and its experimental determining.
8. Impact strength.
9. Toughness and brittleness of a material, their definition and experimental determination.
10. Relaxation.
11. Hardness. The Brinell, Vickers, and Knoop methods of determining the hardness of dental materials, their advantages and disadvantages.
12. Mohs' scale for qualitative determining the hardness of materials.
13. Mechanical properties of tooth tissues.
14. Thermal characteristics of dental materials and tooth tissues, the coefficient of thermal conductivity, the thermal diffusivity, and specific heat. Their importance for dentistry.
15. The linear and volumetric coefficients of thermal expansion, their meaning for right choosing of a restorative material.

Part 2. Physical properties of skin

1. Mechanical properties of skin.
2. Anisotropy of mechanical properties of skin.

Part 3. Principles of rheology

1. Rheological characteristics of liquids and dental materials.
2. Viscosity, Newton's formula for a frictional force. Newtonian and non-Newtonian fluids.
3. Creep, flow.
4. Viscosity of plasma and whole blood.
5. Factors affecting the viscosity of blood.
6. Viscous flow in a cylindrical tube. Poiseuille's law.
7. Linear velocity of the liquid flow and the volume flow rate, the relationship between them. Equation of continuity.

8. Velocity of blood flow in the human circulatory system.
9. Pressure drop in the human circulatory system.
10. The work and power of the heart.
11. Methods of viscosity measurements. Principles of measurements of viscosity with the use of the Ostwald and coaxial cylinder viscometer.

Part 4. Physical basis of adhesion. Current adhesive systems in dentistry

1. Definition of adhesion.
2. Surface tension and its influence on the capacity of a material for an adhesion.
3. Wetting and non-wetting phenomena. Contact angle.
4. Mechanical bonding, the penetration coefficient.
5. Current dental adhesive systems, their classifications.
6. Factors affecting an adhesion to tooth structure.
7. Describe the difference between etch-and-rinse and self-etch adhesives.
8. Mechanism of bonding the adhesive systems to dentin and enamel.

PROBLEMS

1. Calculate the proportional limit and modulus of elasticity from the stress-strain curve for dentin under compression shown in fig. 1.4.
2. A stress of 1 MPa is required to stretch a skin strip of 2 cm long to 2.6 cm. Calculate the modulus of elasticity of the skin sample by assuming the validity of Hooke's law.
3. A compressive force of 600 N is applied to a sample of dentin having cross-sectional area $S = 6 \text{ mm}^2$. What is the stress under this load?
4. The modulus of elasticity of composite restorative material is 10 GPa upon tension, 3846 MPa upon shear. Calculate the Poisson coefficient of the given material.
5. The modulus of elasticity of dentin and enamel are 12 GPa and 46 GPa, proportional limits are 148 MPa and 224 MPa, respectively.
 - 1) Compare the values of the modulus of resilience of enamel and dentin of a molar.
 - 2) What are the values of the strain (ϵ_m) corresponding to the proportional limits of enamel and dentin?
6. Assuming the validity of Hooke's law, calculate the maximum possible strain of enamel of the molar upon compression if the ultimate strength is equal to 305 MPa. Assume the modulus of elasticity of enamel equal to 46 GPa.

7. Which of the following materials will fit closely the stress-strain curves of hard-brittle, ductile-tough and ductile-soft materials shown in fig. 1.10.

- a) ceramics and glasses;
- b) plastics (polyethylene);
- c) soft biological tissues (skin, blood vessel walls);
- d) steels;
- e) hard tissues of tooth;
- f) glassy polymers (polymethylmethacrylate);
- g) rubber.

8. Hardness of enamel measured by Knoop test is KHN 3430 MPa. Calculate the size of indentation (M) if the applied load is equal to 1 N.

9. To fill a cavity, a cylindrical hole with a 3 mm in diameter is made in a molar tooth. The length of the hole is 4 mm and filled with acrylic resin and composite restorative resin.

1) Calculate the volume changes for the fillings upon the temperature variation of 20 °C. Linear coefficients of thermal expansion of acrylic resin, composite restorative resin and dentin are $\alpha_{\text{acryl}} = 81.0 \cdot 10^{-6} \text{ K}^{-1}$, $\alpha_{\text{comp}} = 20.0 \cdot 10^{-6} \text{ K}^{-1}$, $\alpha_{\text{dent}} = 8.3 \cdot 10^{-6} \text{ K}^{-1}$, respectively.

2) Calculate the force developed between the dentine and the fillers. The modulus of elasticity of acrylic resin and composite restorative resin are $E_{\text{acryl}} = 2.5 \text{ GPa}$, $E_{\text{comp}} = 20.0 \text{ GPa}$, respectively.

10. Calculate the volume flow rate of water which flows in a tube with a diameter 25 mm and the length 35 cm. The drop pressure is 48 kPa. The viscosity of water is equal to 1 mPa·s.

11. The volume flow rate of blood in aorta is 500 ml/s. What is the average linear velocity of blood flow in aorta if it has a diameter of 2.0 cm.

12. The velocity of the blood in the aorta is about 0.5 m/s, and the velocity of the blood in a capillary is about 0.001 m/s. We have only one aorta, with a diameter of 20 mm, but many capillaries in parallel, each with a diameter of 8 μm. Estimate how many capillaries are typically open at any one time.

13. Calculate the vascular resistance of the vessel which has diameter of 4 mm and the length of 0.1 m. Assume the viscosity of blood equal to 4 mPa·s.

14. In the circulatory system, the resistance of an arteriole increases when the smooth muscle surrounding the arteriole contracts, thereby decreasing its radius. By what factor does the resistance change if the radius decreases by 10 %?

REFERENCES

1. *Физика* в стоматологии : учеб. пособие / А. А. Иванов [и др.]. Минск : ИВЦ Минфина, 2012.
2. *Philips, R. W.* Science of dental materials / R. W. Philips. USA, 1991.
3. *Park, J. B.* Biomaterials, an Introduction / J. B. Park. N.-Y., L. : Plenum Press, 1979.
4. *Нурт, Р.* Основы стоматологического материаловедения / Р. Нурт. Лондон : Mosby, 2002.
5. *Hobbie, R. K.* Intermediate physics for medicine and biology / R. K. Hobbie, В. J. Roth. Springer, 2006.
6. *Инсарова, Н. И.* Основные понятия теории упругости и сопротивления материалов в стоматологии : учеб. пособие / Н. И. Инсарова, А. А. Иванов, М. В. Гольцев. Минск : БГМУ, 2005.
7. *Храмченко, С. Н.* Современные адгезивные системы : учеб.-метод. пособие / С. Н. Храмченко, Л. А. Казеко, А. А. Горегляд. 2-е изд., перераб. и доп. Минск : БГМУ, 2008.
8. *Strassler, H. E.* Dental adhesives for direct placement composite restorations : an update / H. E. Strassler, M. Mann // www.ineedce.com.
9. *Radovic, C.* Morphological evaluation of 2- and 1-step self-etching system interfaces with dentin / C. Radovic, Z. R. Vulicevic, F. García-Godoy // Operative dentistry. 2006. Vol. 31. № 6.

CONTENTS

Introduction	3
Part 1. Physical properties of dental materials and tissues of tooth	4
1.1. Mechanical properties of dental materials	4
1.2. Mechanical properties of tooth tissues	15
1.3. Thermal properties of dental materials and tissues of tooth	17
Part 2. Physical properties of skin	20
Part 3. Principles of rheology	21
3.1. Rheological characteristics of liquids and dental materials	22
3.2. Blood flow in human circulatory system	27
3.3. Methods of viscosity measurements	33
Part 4. Physical basis of adhesion. Current adhesive systems in dentistry	34
4.1. Factors affecting adhesion.....	35
4.2. Current dental adhesive systems and mechanisms of their bonding to hard tooth tissues	41
Questions	47
Problems	48
References	50

Учебное издание

Никоненко Наталия Анатольевна

Инсарова Наталия Ивановна

**ФИЗИЧЕСКИЕ СВОЙСТВА СТОМАТОЛОГИЧЕСКИХ
МАТЕРИАЛОВ, ТКАНЕЙ ЗУБА И КОЖИ. ЭЛЕМЕНТЫ
РЕОЛОГИИ. ФИЗИЧЕСКИЕ ОСНОВЫ АДГЕЗИИ**

**PHYSICAL PROPERTIES OF DENTAL MATERIALS,
TISSUES OF TOOTH AND SKIN. PRINCIPLES
OF RHEOLOGY. PHYSICAL BASIS OF ADHESION**

Учебно-методическое пособие

На английском языке

2-е издание, исправленное

Ответственный за выпуск В. Г. Лещенко
Переводчики: Н. А. Никоненко, Н. И. Инсарова
Компьютерная верстка Н. М. Федорцовой

Подписано в печать 18.06.15. Формат 60×84/16. Бумага писчая «Снегурочка».

Ризография. Гарнитура «Times».

Усл. печ. л. 3,02. Уч.-изд. л. 2,8. Тираж 90 экз. Заказ 528.

Издатель и полиграфическое исполнение: учреждение образования
«Белорусский государственный медицинский университет».

Свидетельство о государственной регистрации издателя, изготовителя,
распространителя печатных изданий № 1/187 от 18.02.2014.

Ул. Ленинградская, 6, 220006, Минск.